

Control Panels

D9412GV4/D7412GV4/D7212GV4



Trademarks

Trademark names are used throughout this document. In most cases, these designations are claimed as trademarks or registered trademarks in one or more countries by their respective owners. Rather than placing a trademark symbol in every occurrence of a trademark name, Bosch Security Systems, Inc. (hereinafter referred to as Bosch) uses the names only in an editorial fashion and to the benefit of the trademark owner with no intention of infringing the trademark.

Certifications and Approvals

The GV4 Series Literature Pack includes the *D9412GV4/D7412GV4/D7212GV4 Approved Applications Compliance Guide (P/N: F01U201525)*. Refer to this guide for additional guidelines on installing the control panels in Underwriters Laboratories Inc. (UL) and fire-specific applications.

Listings and Approvals

UL

The D9412GV4 and D7412GV4 Control Panels are UL Listed for Central Station, Local, Auxiliary, Proprietary, and Household Fire Alarm, and Central Station, Local, Police Station Connect, Household Burglar Alarm and Encrypted line Security when communicating via a network.

Fire

UL

Underwriters Laboratories, Inc. (UL) lists the D7212GV4 Control Panel as a Control Unit for Household Fire Warning.



The D7212GV4 is not UL Listed for Commercial Fire (UL864).

Burglary

UL

UL lists the D7212GV4 Control Panel for: Central Station, Local, Police Connect, Bank Safe and Vault, Mercantile Safe and Vault, and Household Systems.

Department of Defense (DOD)

The D9412GV4/D7412GV4 was granted approval for Department of Defense (DoD) installations in Sensitive Compartmented Information Facilities (SCIF).

Federal Communications Commission (FCC) Rules

Part 15

This equipment was tested and found to comply with the limits for a Class A digital device, pursuant to Part 15 of the FCC rules. These limits are designed to provide reasonable protection against harmful interference when the equipment is operated in a commercial environment.

This equipment generates, uses, and can radiate radio frequency energy; and if not installed and used according to the instructions, can cause harmful interference to radio communications.

Operation of this equipment in a residential area is likely to cause harmful interference, in which case the user is required to correct the interference at his or her own expense.

Part 68

This equipment complies with Part 68 of FCC rules. A label contains, among other information, the FCC registration number and ringer equivalence number (REN). If requested, this information must be provided to the telephone company.

The D9412GV4, D7412GV4, and D7212GV4 Control Panels are registered for connection to the public telephone network using an RJ38X or RJ31X jack.

The REN is used to determine the number of devices that can be connected to the telephone line. Excessive RENs on the telephone line may result in the devices not ringing in response to an incoming call. In most, but not all areas, the sum of the RENs should not exceed five. To be certain of the number of devices that may be connected to the line, as determined by the RENs, contact the telephone company to determine the maximum REN for the calling area.

If you experience trouble with the control panel, please contact Bosch Security Systems Customer Service for repair and warranty information. If the trouble is causing harm to the telephone network, the telephone company might request that the equipment be removed from the network until the problem is resolved. User repairs must not be made, and doing so will void the user's warranty.

If the D9412GV4, D7412GV4, or D7212GV4 Control Panels causes harm to the telephone network, the telephone company attempts to notify you in advance. If advance notice is not practical, the telephone company notifies you as soon as possible. Also, you will be advised of your right to file a complaint with the FCC if you believe it is necessary.

The telephone company might make changes in its facilities, equipment, operations, or procedures that could affect the operation of the equipment. If this happens, the telephone company provides advance notice in order for the necessary modifications to be made in order to maintain uninterrupted service.

This equipment cannot be used on public coin service provided by the telephone company. Connection to Party Line service is subject to state tariffs. (Contact your state public utilities commission for information.)

FCC Registration Number:

US:ESVOT00BD9412GV4

Service Center in USA:

Bosch ST Service Center
8601 East Cornhusker Hwy
Dock B
Lincoln, NE 68507 - 9702 USA

Ringer Equivalence: 0.0B

Contents

Federal Communications Commission (FCC) Rules	2	4.6.2	Installing and Wiring Detection Devices.	19
1.0 Introduction	7	4.6.3	Installing Modules and Relays	19
2.0 Lightning Strikes	8	4.6.4	Connecting the On-board Points and Keypads	19
2.1 Effects	8	4.6.5	Powering Up	19
2.2 Precautions during Installation	8	4.7	Updating Control Panel Firmware	19
3.0 Overview	9	4.8	Programming the Control Panel	19
3.1 Configuration and Parts	9	4.9	Installing the Point Chart Label	19
3.1.1 Parts List	10	4.10	Testing the System	19
3.1.2 Parts Available by Separate Order	10	4.11	Service Walk Test	20
3.2 Accessories	11	5.0 Power Supply	24	
3.3 Features in the GV4 Series Control Panels	12	5.1 Primary Power Terminals 1 and 2		
3.3.1 SDI Interconnect Wiring	12	5.1.1 Primary (AC) Power Circuit		
3.3.2 Tip and Ring Posts	12	5.1.2 Installing the Transformer		
3.3.3 Telephone Line Sniff	12	5.2 Secondary Power Terminals		
3.3.4 Points	12	5.2.1 Secondary (DC) Power		
3.3.5 Areas and Accounts	12	5.2.2 Installing the Battery		
3.3.6 Digital Communicator	12	5.2.3 Replacing the Battery		
3.3.7 Keypads	13	5.2.4 Battery Supervision		
3.3.8 Keyswitch	13	5.2.5 Battery Charging Circuit		
3.3.9 Access Control (D9412GV4/D7412GV4)	13	5.2.6 Battery Discharge and Recharge Schedule		
3.3.10 Event Memory	14	6.0 Power Outputs	30	
3.3.11 Event Log	14	6.1 Circuit Protection		
3.3.12 Ground Fault Detection	14	6.2 Total Available Power		
3.3.13 Ground Fault Detection Added Feature	14	6.3 Continuous Power Output Terminals 3, 8, 24, and 32		
3.3.14 Conettix Functions	14	6.4 Programmable Power Output Terminals 6, 7, and 8		
3.3.15 Programming	14	6.4.1 Programming		
3.3.16 Dual Authentication	14	6.4.2 Terminals 6 and 7		
3.3.17 Other Features	15	6.4.3 Fire System Power Formula		
4.0 Installation	16	6.4.4 Terminal 8		
4.1 Installation Preparation	16	7.0 Telephone Connections	32	
4.2 Enclosure Options	16	7.1 Registration		
4.3 Mounting Enclosure	16	7.2 Notification		
4.4 Installing the Control Panel	17	7.3 Location		
4.5 Connecting Earth Ground	17	7.4 Telephone Cord Connection		
4.5.1 Terminal 10	17	7.5 Phone LED (Red)		
4.5.2 Ground Fault Detect Enable	17	7.6 Operation Monitor LED (Green)		
4.5.3 Enabling Ground Fault Detection	17	7.7 Dialing Format		
4.5.4 Ground Fault Specifications	17	7.8 Telephone Line Monitor		
4.5.5 Locking the Reset Pin	18	7.9 Called Party Disconnect		
4.6 Completing the Installation	18	7.10 Communication Failure		
4.6.1 Charging the Battery	18	7.11 D928 Dual Phone Line Switcher		
		7.11.1 Description		

7.11.2	Operation	10.1.4	Wiring Connections
7.11.3	Installing the D928	10.2	D811 Arm Status Relay Module
7.11.4	D928 Status LEDs	10.2.1	Relay Output
8.0	On-Board Points.....37	10.2.2	Installation
8.1	Terminals 11 to 22 Description	10.2.3	Wiring Connections
8.2	Point Sensor Loops	10.3	SDI2 Octo-output Relay Modules
8.3	Point Parameters	11.0 Arming Devices 62	
8.4	Point Response Time	11.1	Description
8.5	Wiring Information for Installations Using the Rothenbuhler 5110/4001-42 High Security Bell	11.2	Keypad Terminals 29 to 32
9.0	Off-Board Points40	11.2.1	Assigning an Address for the Keypad
9.1	Zonex Buses	11.2.2	Installation
9.1.1	POPIT Modules	11.3	D279A Independent Zone Control
9.1.2	POPEX Modules	11.4	Keyswitch
9.1.3	Missing Conditions	11.4.1	Description
9.1.4	Control Panel Responses to Missing Point Conditions	11.4.2	Programming
9.2	D8125 and D9127 POPIT Modules	11.4.3	Installation
9.3	Installing the D8125 POPEX Module	11.4.4	Operation
9.3.1	Mounting	12.0 SDI Devices..... 66	
9.3.2	Wiring the D8125 to the Control Panel	12.1	Description
9.3.3	Wiring POPITs to the Data Expansion Loop	12.2	Installation
9.3.4	Wiring Data Expansion Loops to POPEX Modules	12.2.1	Open Wide Trouble on SDI
9.3.5	POPIT Sensor Loops	12.3	D9131A Parallel Printer Interface Module
9.3.6	POPIT Module Point Assignments	12.3.1	Switch Settings
9.3.7	Program Record Sheet	12.3.2	Supervision
9.3.8	POPIT Labels	12.4	D9210C Access Control Interface Module (D9412GV4 and D7412GV4)
9.4	D8128D OctoPOPIT Module	12.4.1	Access
9.4.1	Description	12.4.2	Switch Settings
9.4.2	Listings	12.5	SDI Addresses 88 and 92
9.4.3	Installation	12.5.1	Local RPS Programming
9.4.4	Setting the OctoPOPIT Switches	12.6	SDI Network Interface Modules
9.4.5	Mounting OctoPOPITs	12.6.1	Address Settings
9.4.6	Wiring OctoPOPITs	12.6.2	Supervision
9.4.7	OctoPOPIT Sensor Loops	13.0 SDI2 Devices..... 69	
9.5	Testing Off-Board Points	13.1	Description
9.6	SDI2 Octo-input Point Modules	13.2	Installation
9.7	Extra Point Events	13.2.1	Open Wire Trouble on SDI2
10.0 Off-Board Relays56		13.3	B208 Octo-input Module
10.1	D8129 OctoRelay	13.3.1	Address Settings
10.1.1	Configuring the D8129 OctoRelay	13.3.2	Supervision
10.1.2	Relay Outputs	13.4	B308 Octo-output Module
10.1.3	Installation	13.4.1	Address Settings
		13.4.2	Supervision
		13.5	B420 Ethernet Communication Module

13.5.1	Address and Emulation Settings	
13.5.2	Supervision	
13.5.2	Local RPS Programming	
13.5.3	Ethernet Communications Module Faults	
13.6	B820 SDI2 Inovonics Interface Module	
13.7.1	Supervision	
13.7.2	Wireless Receiver Faults	
13.7.3	Wireless Repeaters Faults	
14.0	Installer Keypad Tools	73
14.1	RPS Access Reports	
15.0	Accessory Connector	74
16.0	Faceplates	75
16.1	GV4 Series Faceplate	
Appendix A: System Wiring Diagrams		76
A.1	Power Supply Side System Wiring	
A.2	Input Points and Peripheral Devices Wiring Diagrams	
A.3	SDI and Zonex Devices System Wiring System Wiring	
Appendix B: Point Address Charts		81
B.1	Zonex 1 Points	
B.2	Zonex 2 Points	
B.3	SDI2 Points	
Appendix C: Specifications		84
C.1	Control Panel Power Supply	
C.2	Terminal Wiring	

Figures

Figure 1:	System Configuration
Figure 2:	Enclosure Mounting
Figure 3:	Enabling Ground Fault Detection
Figure 4:	Reset Pin
Figure 5:	Service Walk Test Flow Chart Example
Figure 6:	Battery Terminals
Figure 7:	Non-Power-Limited Wiring
Figure 8:	Charging and Battery LEDs
Figure 9:	RJ31X Wiring
Figure 10:	Phone Connector, Phone LED, and Operation Monitor LED Locations
Figure 11:	D928 Dual Phone Line Switcher
Figure 12:	On-board Point Sensor Loop Wiring
Figure 13:	Wiring the Rothenbuhler 5110/4001-42 High Security Bell to the Control Panel

Figure 14:	Connecting the D8125 POPEX to the D9412GV4 Control Panel
Figure 15:	Connecting the D8125 POPEX to the D7412GV4 and D7212GV4 Control Panels
Figure 16:	D8128D OctoPOPIT Layout
Figure 17:	Connecting D8128D OctoPOPITs to the D9412GV4
Figure 18:	Connecting D8128D OctoPOPITs to the D7412GV4 or D7212GV4
Figure 19:	Wiring Multiple D8128Ds Using Interconnect Wiring
Figure 20:	D8128D OctoPOPIT Sensor Loops
Figure 21:	D8129 Connections to the D9412GV4
Figure 22:	D8129 Connections to the D7412GV4 or D7212GV4
Figure 23:	D811 Arm Status Relay Module Wiring to the D9412GV4
Figure 24:	D811 Arm Status Relay Module Wiring to the D7412GV4 or D7212GV4
Figure 25:	External Power to SDI Devices
Figure 26:	Keyswitch Wiring
Figure 27:	DX4020 DIP Switch Settings
Figure 28:	B208 Switches Set to Address 9
Figure 29:	B308 Switches Set to Address 9
Figure 30:	B420 Switch Set to Address 1
Figure 31:	B820 Switch Set to Address 1
Figure 32:	Accessory Connection on D9412GV4 and D7412GV4
Figure 33:	D9412GV4/D7412GV4/D7212GV4 Faceplate
Figure 34:	D9412GV4/D7412GV4/D7212GV4 Power Supply Side System Wiring (Power and Phone)
Figure 35:	D9412GV4/D7412GV4/D7212GV4 Input Points and Peripheral Devices System Wiring
Figure 36:	D9412GV4 SDI and Zonex Devices System Wiring System Wiring
Figure 37:	D7412GV4/D7212GV4 SDI and Zonex Devices System Wiring
Figure 38:	D9412GV4/D7412GV4/D7212GV4 SDI2 Devices System Wiring

1.0 Introduction

This manual addresses the operation and installation of the GV4 Series Control Panels. Throughout this guide, the words “control panel” refer to all control panels (D9412GV4, D7412GV4 and D7212GV4). *Table 2* on page 9 provides an overview of the differences in the control panels.



To obtain any of the documents in *Table 1*, contact Bosch Security Systems, Inc. Customer Service at (800) 289-0096 and request the documentation by its corresponding part number.

Table 1: Related Documentation

Product Type	Name of Documentation	Part Number
Control Panels	<i>D9412GV4/D7412GV4/D7212GV4 Panels Release Notes</i>	F01U215243
	<i>D9412GV4/D7412GV4/D7212GV4 Approved Applications Compliance Guide</i>	F01U201525
	<i>D9412GV4/D7412GV4/D7212GV4 Installation and Operation Guide (this document)</i>	F01U201527
	<i>D9412GV4/D7412GV4/D7212GV4 Program Entry Guide</i>	F01U218312
	<i>D9412GV4/D7412GV4/D7212GV4 Program Record Sheet</i>	F01U214958
	<i>UL Certificated Bank Safe and Vault Applications Technogram</i>	73-07302-000
Keypads	<i>D1255RB/D1256RB/D1257RB Installation Instructions</i>	F01U011791
	<i>D1255/D1255B Installation Instructions</i>	74-06819-000
	<i>D1256/D1257 Installation Instructions</i>	74-06925-000
	<i>D1260/D1260B Installation Guide</i>	48101
	<i>D1260/D1260B Owner's Manual</i>	50410
	<i>D720 Series Installation Instructions</i>	74-06918-000
	<i>D279A Operation and Installation Instructions</i>	46458
	<i>Security System Owner's Manual</i>	71-06633-000
Programming Tools	<i>D9412GV4/D7412GV4/D7212GV4 Owner's Manual Supplement</i>	F01U245224
Expansion Devices	<i>RPS Installation Guide</i>	4998141259
	<i>D8128D Installation Guide</i>	F01U070537
	<i>D8125MUX Operation & Installation Guide</i>	F01U034973
	<i>ISW-D8125CW-V2 Installation & Operation Guide</i>	F01U161691
	<i>D9210C Operation and Installation Guide</i>	F01U215232
	<i>B208 Octo-input Module Installation and Operation Guide</i>	F01U215232
	<i>B308 Octo-output Module Installation and Operation Guide</i>	F01U215235
	<i>B820 SDI2 Inovonics Interface Module Installation Guide</i>	F01U215241
<i>B420 Ethernet Communication Module Installation and Operation Guide</i>	F01U215236	

2.0 Lightning Strikes

The control panels are designed to significantly reduce electromagnetic interference and malfunction generally caused by lightning.

2.1 Effects

Any electronic system can be struck directly by lightning or be adversely affected by a lightning strike near the system. When lightning strikes, several things happen:

- An electromagnetic wave spreads from the point of the strike inducing high voltages in nearby conductors.
- The voltage changes substantially on electrical grounds near the lightning strike.
- High voltages are induced in anything directly struck by lightning.

The effects of a lightning strike can include Missing Trouble, Missing Alarm, or Point Bus Trouble events. Occasionally, Reboot and Watchdog events might be sent because the control panel tried to reset itself.

Electronic systems, including control panels, cannot be completely immune to direct or indirect lightning strikes; however, some proven installation practices might greatly reduce the risk of undesirable affects.

2.2 Precautions during Installation

To minimize the risk of undesirable effects from lightning strikes on high risk installations that use a point-bus technology:

- Do not run wiring outside the building.
- If you must install the unit in a metal building, keep the wiring at least 0.61 m (2 ft) away from external metal surfaces.
- Earth ground the unit correctly. Do not use an electrical ground or telephone ground.
- Avoid running wires near telephone, data, or power lines inside a building. Historical evidence shows that locating control panel wiring at least 0.61 m (2 ft) away from telephone, data, or power lines is successful at minimizing lightning damage. When your data lines must cross the path of AC or other wiring, cross the lines perpendicularly.

3.0 Overview

3.1 Configuration and Parts

Figure 1: System Configuration

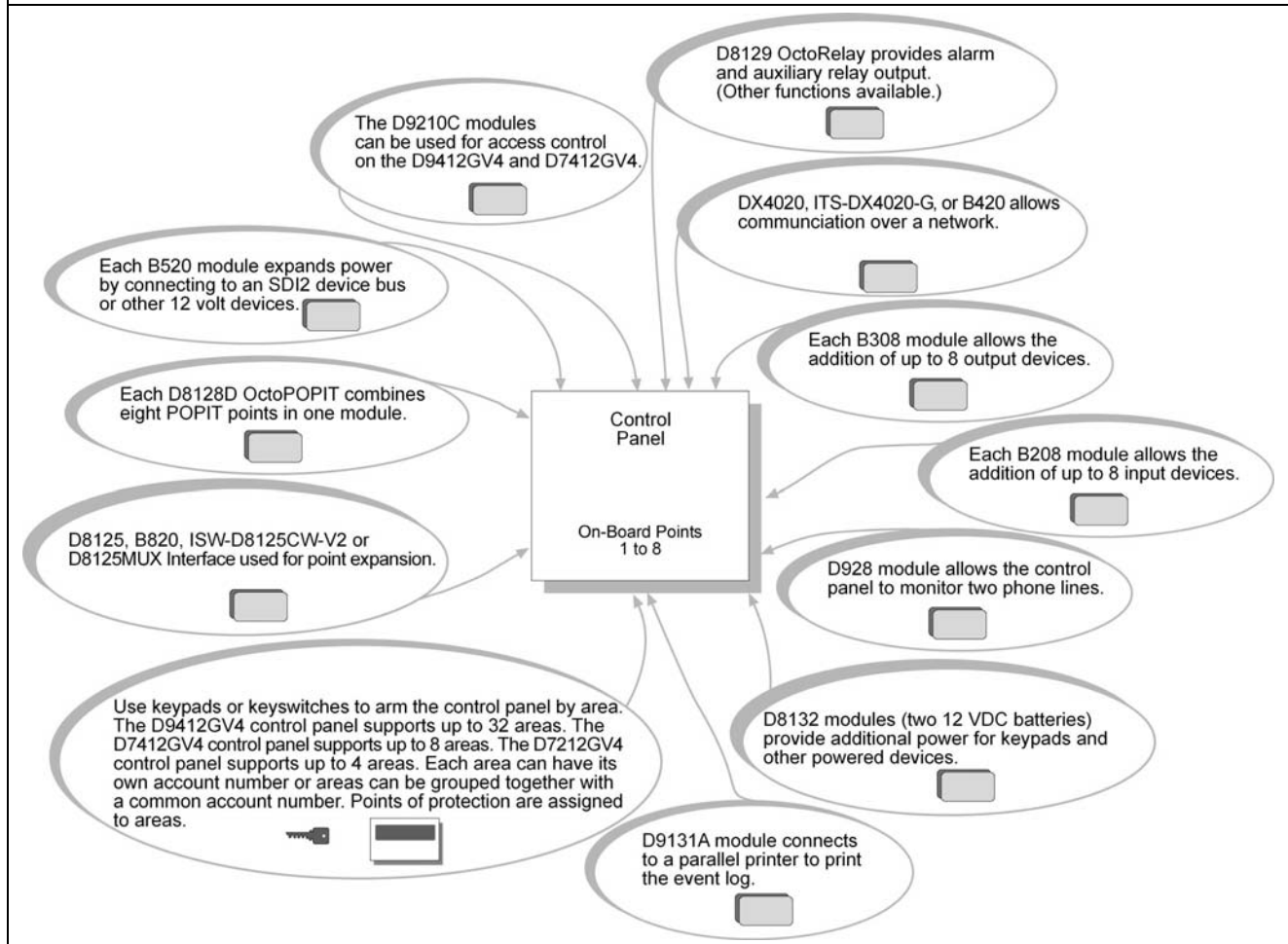

Table 2: Control Panel Differences

Features	D9412GV4	D7412GV4	D7212GV4
Access Control	Yes - 8 doors	Yes - 2 doors	No
Arm/Disarm Passcodes	999	399	99
Cards/Tokens	999	399	N/A
Passcode-Protected Custom Functions	16	4	4
Number of Printers	3	1	1
Number of Points	246	75	40
Number of Off-board Relays	128	64	24
Number of Areas	32	8	4
Number of D1255 Keypads	16	16	8
Number of D1260 Keypads	8	8	8
Number of Phone Lines Supported	2	2	1

3.1.1 Parts List

The control panels are shipped assembled from the factory with the following parts:

Literature Pack

- *D9412GV4/D7412GV4/D7212GV4 Program Record Sheet* (P/N: F01U214958)
- *7000/9000 Series Point Chart Label* (P/N: 79-06660-000)

Assembly

- PC board
- Faceplate shield
- Mounting skirt
- One #6 x 1/4-in. screw

3.1.2 Parts Available by Separate Order

Order the following components separately to complete a basic eight-point installation.



The D1260 and D1260B Keypads must have firmware version 1.04 or higher for use with the GV4 Series Control Panels.

- D1255B, D1255, D1256, D1260, D1260B Keypad, or D720 Keypad
- D1255RB Fire Keypad, D1256RB Fire Keypad, or D1257RB Fire Alarm Annunciator
- D1640 Transformer
- D126 or D1218 Battery
- D161 or D162 Phone Cord (order two cords if using the D928 Dual Phone Switcher)
- D8103, D8108A, or D8109 Enclosure

Configured packages are also available. Please consult the Bosch Security Systems, Inc. Product Catalog.

The following literature is available in a separate literature package for dealers.

- *D9412GV4/D7412GV4/D7212GV4 Operation and Installation Guide* (P/N: F01U201527)
- *D9412GV4/D7412GV4/D7212GV4 Approved Applications Compliance Guide* (P/N: F01U201525)
- *D9412GV4/D7412GV4/D7212GV4 Program Entry Guide* (P/N: F01U218312)
- *D9412GV4/D7412GV4/D7212GV4 Program Record Sheet* (P/N: F01U214958)

3.2 Accessories

Refer to the Bosch Security Systems, Inc. product catalog for additional information.

Model	Title	UL 864	Fire	Intrusion
B208	Octo-input Module	X	X	X
B308	Octo-output Module	X	X	X
B420	Ethernet Communication Module	X	X	X
B820	SDI2 Inovonics Interface Module	X	X	X
D122/D122L/D122/ D122LL	Dual Battery Harness	X	X	X
D125B	Powered Loop Interface Module	X	X	X
D127	Reversing Relay	X	X	X
D129	Dual Class A Initiation Circuit Module	X	X	X
D130	Relay Module	X	X	X
D185	Reverse Polarity Module		X	X
D192G	Bell Circuit Supervision Module	X	X	X
D279A	Independent Zone Control (On-Board and OctoPOPIT Points)			X
D720R	LED Keypad (red)		X	X
D720W	LED Keypad (white)		X	X
D928	Dual Phone Line Switcher	X	X	X
D1255RB	Fire Keypad	X	X	X
D1256RB	Fire Keypad	X	X	X
D1257RB	Fire Alarm Annunciator	X	X	X
D1218	12 V, 17.2 Ah Rechargeable Battery	X	X	X
D1255/D1255B	Keypads (General Purpose)		X	X
D1255R	Text Keypad (red)		X	X
D1255W	Text Keypad (white)		X	X
D1256	Fire Keypad		X	
D1257	Fire Alarm Annunciator		X	
D1260/D1260B ²	Keypads		X	X
D1640	16.5 VAC 40 VA Transformer	X	X	X
D8004	Transformer Enclosure	X	X	X
D8125	POPEX Module	X	X	X
D8125MUX	Multiplex Bus Interface	X	X	X
D8128D	OctoPOPIT Module	X	X	X
D8129	OctoRelay Module	X	X	X
D8130	Release Module	X	X	X
D8132	Battery Charger Module		X	X
D9127U/T	POPIT Module	X	X	X
D9131A	Parallel Printer Interface Module		X	X
D9210C	Access Control Interface Module	X	X	X
DX4020	Network Interface Module	X	X	X
ITS-DX4020-G	GPRS/GSM Communicator	X	X	X
ICP-SDI-9114	SDI Splitter	X	X	X
ISW-D8125CW-V2	Commercial Wireless Interface Module			
ZX776Z	PIR Motion Sensor [15 m (50 ft)] with POPIT			X
ZX794Z	PIR Motion Sensor [24 m (80 ft)] with POPIT			X
ZX865	PIR/Microwave Motion Sensor [+1.7°C (+35°F)] with POPIT			X
ZX938Z	PIR Motion Sensor [18 m (60 ft)] with POPIT			X
ZX970	PIR/Microwave Motion Sensor [+1.7°C (+35°F)] with POPIT			

¹ Where the fire alarm transmitter is sharing on-premise communications equipment, the shared equipment must be UL Listed (ITE or fire protective signaling). ² Version 1.04 or above

3.3 Features in the GV4 Series Control Panels

3.3.1 SDI Interconnect Wiring

Use interconnect wiring to easily connect an SDI bus device to the SDI bus or an SDI2 device to the SDI2 bus without needing to disconnect wires connected to the bus terminals. Possible applications include:

- Connecting a DX4010i to program the control panel with Remote Programming Software (RPS) at the premises
- Connecting a keypad to test the control panel.



UL requires that the DX4010i be used for programming only.

3.3.2 Tip and Ring Posts

The tip and ring posts allow connecting a phone or buttset for the purpose of troubleshooting communications between the control panel and the central station. This connection allows monitoring of the dial tone, handshaking tones from the receiver, and communications signals.

3.3.3 Telephone Line Sniff

The control panels monitor the phone line for the programmed supervision interval before indicating a phone line trouble.

3.3.4 Points

The Bosch Security Systems, Inc. D9412GV4 Control Panel provides up to 246 points of protection. The D7412GV4 Control Panel provides up to 75 points of protection. The D7212GV4 Control Panel provides 40 points of protection. Point programming parameters determine the control panel's response to open and shorted conditions on the sensor loop for the point. Several options allow individual point programming to custom-fit the protection to the installation.

Points 1 to 8 are located on the circuit board (on-board points). They are standard sensor loops. The remaining off-board points can be located on point expansion modules on a ZONEX bus or an SDI bus. The ZONEX bus supports any combination of POPIT points using D8128D OctoPOPITs, D8125 POPEX Modules and D9127 POPITs, a ISW-D8125CW-V2 Commercial Wireless

Interface Module, or D8125MUX Modules. The SDI2 bus supports any combination of B208 Octo-input modules, or a B820 SDI2 Inovonics Interface Module.



Any points programmed as fire supervisory points are latching.

3.3.5 Areas and Accounts

The D9412GV4 supports up to 32 areas. The D7412GV4 supports up to 8 areas. The D7212GV4 supports up to 4 areas. You can assign all points to a single area or distribute them over all supported areas.

The control panel is armed and disarmed by area, and several areas can be armed and disarmed with one menu function. A passcode can also be assigned an authority level that allows a user to arm an area from a remote keypad in another area. Assigning each area its own account number creates up to 32 separate accounts in the D9412GV4, up to 8 separate accounts in the D7412GV4 and up to 4 separate accounts in the D7212GV4. Assigning the same account number to different areas groups them together in a single account.

Area options include exit tone and delay, separate fire and burglary outputs, and multiple opening and closing windows. Area type can be used to create area interdependencies for arming purposes.

3.3.6 Digital Communicator

The control panel uses a built-in digital communicator to send reports to the receiver. The control panel sends reports in either the Modem IIIa² or ANSI-SIA Contact ID format. All software versions for the D6600 can be used with the control panel.

The control panel connects to an RJ31X or RJ38X jack for telephone line seizure. Connecting to the RJ31X complies with FCC regulations for using the public telephone network. The control panel can be programmed to direct reports to four separate telephone numbers. Adding the D928 Dual Phone Line Switcher Module to the D9412GV4 or the D7412GV4 allows connection and supervision of a second telephone line.

The system can route groups of Event Reports to four different destinations through the phone or over a network. Each report group can be programmed to send reports to one or more destinations. Primary and backup reporting paths can be programmed for each destination and each report group. A custom option allows specification of individual Event Reports to be sent.

3.3.7 Keypads

Up to 32 unsupervised keypads can be connected to the system. The available power, number of supervised keypads, and number of areas covered affect the total number of keypads that can be connected.

The system can supervise up to sixteen D1255 keypads (D9412GV4 and D7412GV4) or eight D1255 keypads (D7212GV4), and up to eight D1260 keypads (all models). The control panel sends a Serial Device Trouble Report, SDI FAILURE in the Modem IIIa² format or Expansion Module Failure (333) in Contact ID format, if it loses communication with a supervised keypad.

More than 16 keypads can be added, but the system can only supervise up to 16 keypads (D9412GV4 and D7412GV4) or 8 keypads (D7212GV4). *Table 4* on page 13 shows the keypads that are compatible with the GV4 Series Control Panels. Refer to the *D9412GV4/D7412GV4/D7212GV4 Program Entry Guide (P/N: F01U218312)* for complete details on programming keypad options.



UL requires all Fire System keypads to be supervised.

Table 4: Compatible Keypads

Model	Display	Application
D1255/ D1255B/ D1255RB	16-character alphanumeric	Fire/Burglary/Access
D1256/ D1256RB	16-character alphanumeric	Fire
D1257/ D1257RB	16-character alphanumeric	Fire
D1260/ D1260B	4-line by 20-character	Fire/Burglary
D720/ D720B	8 LED	Fire/Burglary

3.3.8 Keyswitch

Maintained or momentary closure devices such as keyswitches allow any of the available areas to be armed or disarmed. Point programming determines the loop responses and which area a keyswitch controls.

3.3.9 Access Control (D9412GV4/D7412GV4)

The D9412GV4 can control eight access doors (each requiring the optional D9210C Access Control Interface Module) with up to 999 uniquely identified cards or tokens. The D7412GV4 can control two access doors with up to 399 uniquely identified cards or tokens. Any of the following can grant access:

- Wiegand-style access control device (card reader) connected to the D9210C Access Control Interface Module
- Request to enter (RTE) or request to exit (REX) input
- Unlock command on a keypad

The access control features of the D9412GV4 and D7412GV4 can deny access during armed periods. The control panel can also grant access only to certain authorized users depending on whether the area is master armed, perimeter armed, or disarmed. Programming for automatic disarming when designated authorized users are granted access is also possible.

The Dual Authentication feature can optionally require passcode entry with presentation of door credentials before access authorization is granted.

3.3.10 Event Memory

The control panel retains point alarm and trouble events in memory for each area. A D1255 (any model) or a D1260 (any model) can be used to view event memory by using COMMAND 40. The control panel clears the previous events for an area from the event memory when the area is armed.

3.3.11 Event Log

The system stores 1023 events from all areas in its event log. For example, the system adds at least two items to the log each time an area is armed or disarmed, the open (or close) event that also contains the previous arming state.

All events can be stored even if the control panel does not send a report for them. The log can be viewed at a keypad, printed locally using the D9131A Parallel Printer Interface Module and a parallel printer, or uploaded using Remote Programming Software (RPS).

For a list of the log events, refer to the appendix in the user's guide for the keypad.

3.3.12 Ground Fault Detection

The Earth Ground Terminal on the control panels is electrically isolated from all other terminals to allow the control panels to detect ground fault conditions. A Ground Fault Detect Enable switch (S4) is located just under Terminal 10, Earth Ground, on the control panel. Refer to *Section 4.5.2 Ground Fault Detect Enable* on page 17 for information on operating this function.

3.3.13 Ground Fault Detection Added Feature

When Ground Fault Detect is enabled (S4 closed), Points 1 to 8 can be used for non-powered fire-initiating devices such as heat detectors, four-wire smoke detectors, and pull stations. A D125B Powered Loop Interface or a D129 Dual Class A Interface Module is not required when connecting the non-powered fire-initiating devices to Points 1 to 8.

3.3.14 Conettix Functions

The D6600 Conettix System supports data network communications. Conettix allows the D6600 Receiver to connect to various network technologies including Ethernet and GPRS (General Packet Radio System). Connecting to a data network is possible using the COM4 or COM1 connection from the D6600 Receiver to the D6680 Network Adapter. Control panels can send reports through telephone lines, Ethernet, or GPRS networks to the D6600 receiver at the central station. Once events are received, they can then be issued to automation software or a network printer through a local area network (LAN) or wide area network (WAN).

Sending events to the central station over a LAN or WAN requires a network interface module (NIM), such as the DX4020. Sending events over GPRS requires a special NIM, the ITS-DX4020-G.

3.3.15 Programming

Use the Remote Programming Software (RPS), or the local Programmers Menu, to program the control panels. Refer to the *D9412GV4/D7412GV4/D7212GV4 Program Entry Guide (P/N: F01U218312)* for programming options.

3.3.16 Dual Authentication

The D9412GV4 and D7412GV4 control panels can be configured to require two forms of identification before processing certain system commands. This feature requires a door controller and a keypad to be installed within proximity to each other for user convenience.



Dual Authentication requires a door controller module even though the configured operation may not be access.

A standard system user has authority to use Dual Authentication if they have a passcode, a door credential (token or card), and appropriate command authority permissions assigned in the door and keypads assigned area. When enabled at a keypad, only the following Passcode Functions require access credentials with passcode entry, Arm / Disarm, Cycle Door (Grant Access), Cycle Relay, and Auto Re-arm. Refer to the *D9412GV4/D7412GV4/D7212GV4 Program Entry Guide (P/N: F01U218312)* and *D9210C Installation and Operation Guide (P/N:*

F01U215232) for details on installation, configuration and operation of this feature.

3.3.17 Other Features

The GV4 Series Control Panels have many programmable features. Some of the features are listed below. Complete details on all features are in the *D9412GV4/D7412GV4/D7212GV4 Program Entry Guide (P/N: F01U218312)*

- Supervision of AC (primary power), battery (secondary power), Zonex SDI and SDI2 buses, central processing unit (CPU), up to three printers, and two telephone lines
- Automatic System Test Reports
- Remote access for programming, diagnostics, and log uploads using the remote programming software (RPS)
- Fire alarm verification
- Programmable alarm output
- Programmable relay output using the D8129 OctoRelay Module or the B308 Octo-output Module
- Opening and closing windows
- Skeds (scheduled events)
- Limited local programming available in the Service Menu

4.0 Installation

4.1 Installation Preparation

This section contains a general installation procedure and refers to other sections of the document for detailed instructions.

Review this document and the *D9412GV4/D7412GV4/D7212GV4 Program Entry Guide* (P/N: F01U218312) before beginning the installation to determine the hardware and wiring requirements for the features used.

Have the following documentation available when reading through this guide:

- *D9412GV4/D7412GV4/D7212GV4 Program Record Sheet* (P/N: F01U214958)
- *Security System Owner's Manual* (P/N: 71-06633-000) and *Owner's Manual Supplement* (P/N: F01U245224) for GV4 Series Control Panels for keypad or annunciator (D1255 all models, D1255RB, D1256, D1256RB, D1257, D1257RB, D1260 all models, or D720 all models)

Before installation, become familiar with the operation of RPS or the local Programmers menu.

4.2 Enclosure Options

Mount the control panel assembly in any of the Bosch Security Systems, Inc. enclosures listed:

- D8103 Universal Enclosure (tan)
- D8109 Fire Enclosure (red)
- D8108A Attack Resistant Enclosure (tan)

Refer to the *D9412GV4/D7412GV4/D7212GV4 Control Panels Approved Applications Compliance Guide* (P/N: F01U201525) to determine if the application requires a specific enclosure.

4.3 Mounting Enclosure

1. Run the necessary wiring throughout the premises.
2. Mount the enclosure in the desired location. Use all five enclosure mounting holes. Refer to *Figure 2*.
3. Pull the wires into the enclosure.



Electromagnetic interference (EMI) can cause problems on long wire runs.

Figure 2: Enclosure Mounting

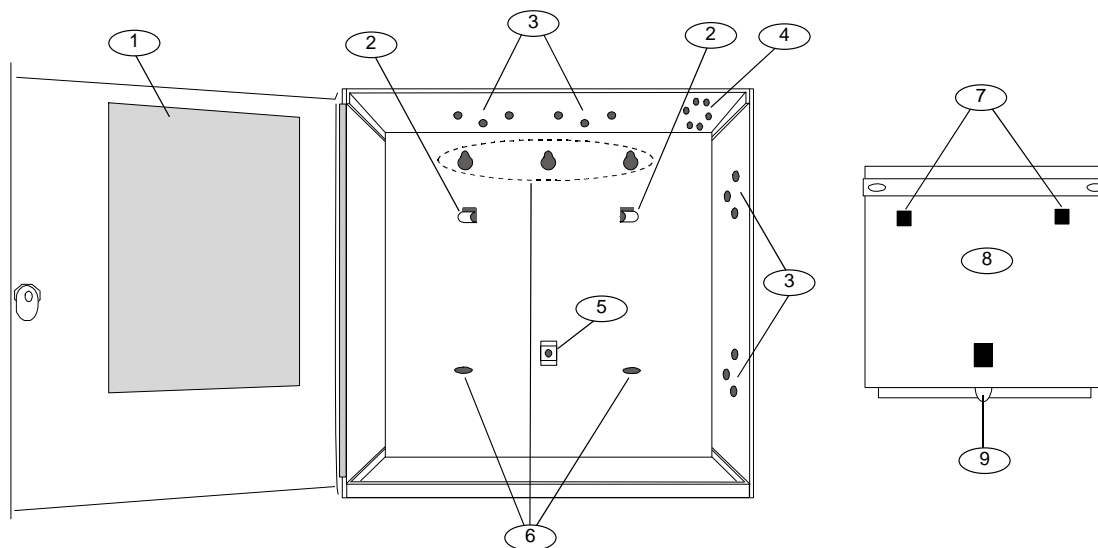

1 - Point chart label

2 - Mounting skirt hooks (2)

3 - Module mounting holes (12)

4 - Tamper switch mounting holes (5)

5 - Skirt mounting hole (1)

6 - Enclosure mounting holes (5)

7 - Mounting skirt hook holes (2)

8 - Back of D9412GV4/D7412GV4 Control Panel

9 - Lock down tab

4.4 Installing the Control Panel

1. Place the control panel over the inside back of the enclosure, aligning the large rectangular openings of the mounting skirt with the mounting hooks of the enclosure. Slide the control panel down so that it hangs on the hooks. Refer to *Figure 2, Item 2* on page 16.
2. Remove the tape from the #6 x 1/4-in. screw in the mounting tab on the control panel. The screw passes through the mounting tab and into the skirt mounting hole in the enclosure. Tighten the screw to secure the control panel in the enclosure.
3. Connect earth ground to the control panel before making any other connections. Refer to *Section 4.5 Connecting Earth Ground*.

4.5 Connecting Earth Ground

4.5.1 Terminal 10

To help prevent damage from electrostatic charges or other transient electrical surges, connect the system to earth ground at Terminal 10 before making other connections. Recommended earth ground references are a grounding rod or a cold water pipe.



Caution: Do not use telephone or electrical ground for the earth ground connection. Use 1.8 mm (14 AWG) to 1.5 mm (16 AWG) wire when making the connection.

Do not connect other control panel terminals to earth ground.

4.5.2 Ground Fault Detect Enable



To meet UL 864 requirements, enable Ground Fault Detect.

A ground fault is a circuit impedance to earth ground. The control panel has a ground fault detection circuit that, when enabled, detects ground faults on Terminals 1 to 9 and 11 to 32. The control panel also detects and annunciates ground faults on any device connected to it.

If a ground fault condition occurs, the keypads display SERVC GND FAULT and the control panel transmits a GROUND FAULT TROUBLE, AREA 1.

When the control panel recognizes that the ground fault condition is corrected, and remains corrected for between 5 to 45 consecutive sec, a Restoral Report is sent.



The D9412GV4 and D7412GV4 Control Panels log and print a Ground Fault event as a Trouble Point 256 if communicating in Modem IIIa² format. If communicating in Contact ID format, the control panels generate a Ground Fault (310) event.

4.5.3 Enabling Ground Fault Detection

To enable Ground Fault Detect Enable, lock (close) the S4 Ground Fault Detect Pin on the control panel (*Figure 3*).

Figure 3: Enabling Ground Fault Detection

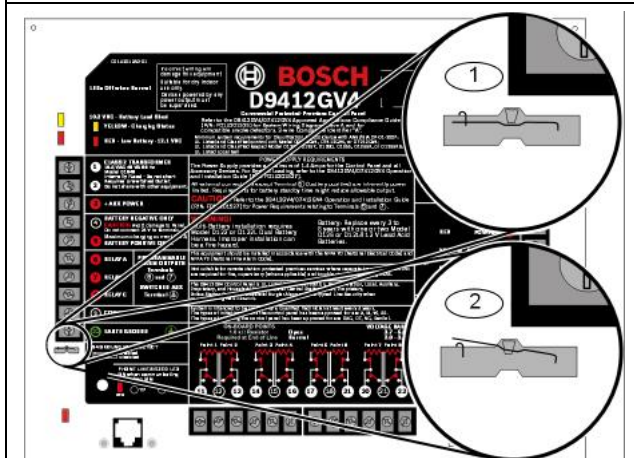

1 - S4 Locked (Closed). Control panel detects ground faults.

2 - S4 Unlocked (Open). Control panel does not detect ground faults.

4.5.4 Ground Fault Specifications

Table 5 provides the impedance specifications for detecting ground faults when any terminal or field wiring is shorted to ground.

Impedance	Control Panel Detects Ground Fault
≤ 300 Ω	Yes
300 Ω to 200 kΩ	Detection depends upon the terminal
≥ 200 kΩ	No

4.5.5 Locking the Reset Pin

Locking the reset pin disables the control panel (Figure 4). When the control panel is disabled, the system ignores most keypad commands and points. CALL FOR SERVICE appears in keypad displays when the pin is locked down.

On-board relays (Terminals 6 and 7) and off-board relays deactivate when the control panel is reset. Terminal 8 has power when the relay is deactivated. Activation interrupts power at that terminal. The on-board relay (Terminal 8) remains deactivated when the reset pin is locked in the disable position.

Releasing the reset pin from the closed position resets the control panel. The control panel resets all its timers, counters, indexes, and buffers. Any points that restore after a reset do not generate Restoral Reports.

If the reset pin is placed in the disable position when all areas are armed, there must be an entry in the Answer Armed program item. Refer to *RPS Parameters* in the *D9412GV4/D7412GV4/D7212GV4 Program Entry Guide* (P/N: F01U218312).

Locking the pin in the disable position applies power to the control panel and charges the battery while the detection devices and keypads are installed.

Figure 4: Reset Pin

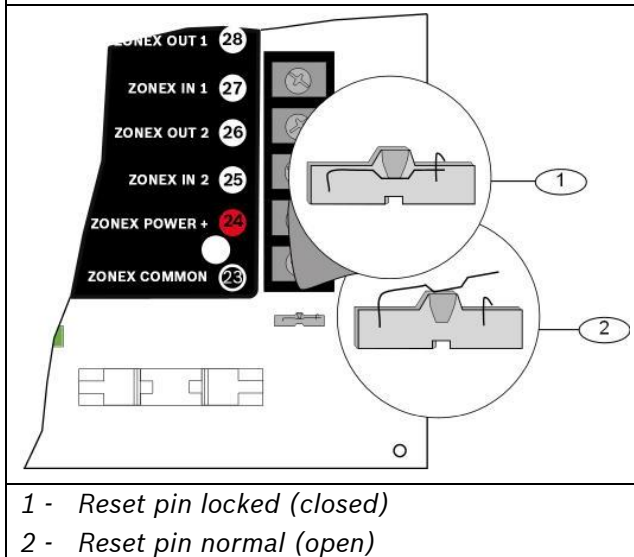

4.6 Completing the Installation

If not already complete, make the earth ground connection to Terminal 10 and lock the reset pin in the closed position.

4.6.1 Charging the Battery

Connect the battery, then the transformer to allow the control panel to charge the battery while you complete the installation. Refer to *Section 5.0 Power Supply* on page 24 for instructions.

On-board Buzzer Sounds at Power Up and Reset:

The system performs a series of self-diagnostic tests of hardware, software, and programming at power up and at reset. The buzzer on the control panel sounds during the tests. The self-diagnostics tests complete in approximately 1 to 3 sec.

If the control panel fails any test, the buzzer continues sounding and a System Trouble message appears at the keypads.

Touch Terminal 10 First: If the on-board buzzer sounds briefly when the control panel is touched, any static charge you carry discharges to the control panel.

Avoid electrostatic discharge. Always touch Terminal 10, the earth ground connection, before beginning work on the control panel.

If the control panel receives an electrostatic discharge, it might generate Watchdog Reset and Param Fail events.

4.6.2 Installing and Wiring Detection Devices

Install and wire detection devices and keypads at their locations throughout the premises. **Do not** connect the control panel yet.

Section 8.0 On-Board Points on page 37 contains instructions for wiring the on-board points to detection devices. *Section 11.0 Arming Devices* on page 62 contains instructions for wiring the keypads.

Instructions for wiring the off-board point POPIT sensor loops are found in the instructions packaged with the POPIT modules.

4.6.3 Installing Modules and Relays

1. Power down the unit by unplugging the transformer and disconnecting the battery.



Always power down the unit when installing modules or relays, or when making wiring connections to the control panel.

2. Install and wire any modules required for the installation as described in the module's installation instructions.

Instructions for the D8125 POPEX Module, D8128D OctoPOPIT Module, D8129 OctoRelay Module, D811 Arm Status Relay Module, and D928 Dual Phone Line Switcher appear in this guide.

Refer to *Section 9.0 Off-Board Points* on page 40 for D8125 and D8128D instructions. Refer to *Off-Board Relays* on page 54 for D8129 and D811 instructions. Refer to *Section 7.11 D928 Dual Phone Line Switcher* on page 34 for D928 instructions.

3. If using the power outputs at Terminals 7 or 8, refer to *Section 6.4 Programmable Power Output Terminals 6, 7, and 8* on page 30 for instructions.

4.6.4 Connecting the On-board Points and Keypads

Connect the on-board points and keypad wiring to the system. Refer to *Section 8.0 On-Board Points* on page 37 and *Section 11.0 Arming Devices* on page 62 for instructions.

4.6.5 Powering Up

Reconnect the battery, then plug in the transformer. The buzzer sounds for two sec when the control panel is powered up. Leave the reset pin in the locked position.

Yellow Charging Status LED Remains Lit: If the yellow charging status LED remains lit after five minutes of powering up the control panel, either the battery is deeply discharged or too many powered devices were connected to the control panel. Combined continuous current draw for Terminals 3, 8, 24, and 32, and the accessory connector cannot exceed 1.4 A. Refer to *Section 6.0 Power Outputs* on page 30 for help.

4.7 Updating Control Panel Firmware

When a firmware update is available, installation of the update is performed using either a ROM Update Key or using RPS. Refer to the *D9412GV4/D7412GV4/D7212GV4 ROM Update Key Instructions* on the underside of the control panel faceplate, or refer to *RPS Online Help*.

4.8 Programming the Control Panel

If the control panel is not already programmed, review the *D9412GV4/D7412GV4/D7212GV4 Program Entry Guide (P/N: F01U218312)*. Ensure that all accessory modules for desired features are available for installation.

Use RPS to load a custom program into the control panel as needed.

4.9 Installing the Point Chart Label



The point chart label is required for fire systems with verifications points.

A point chart label is included in the literature pack. Install the point chart label for fire or combined fire-and-burglary systems that use verification points.

Use the *D9412GV4/D7412GV4/D7212GV4 Program Record Sheet (P/N: F01U214958)* to gather the necessary information for completing the point chart. Fill out the label and install it on the inside of the enclosure door (refer to *Figure 2* on page 16).



Avoid smearing the entries on the chart. Use the peel-off backing to press the label in place.

4.10 Testing the System

After installing and programming the control panel, test the system completely. Test the control panel and all devices for proper operation.



Test after initially programming the control panel.

To meet UL 864 requirements, perform a full system test after any subsequent programming session.

Refer to *Section 4.11 Service Walk Test* on page 20 for complete Service Walk Test instructions.

Clear after Test: To clear the event memory and report buffer, momentarily close the reset pin. Events stored in the control panel's event log are not cleared.

4.11 Service Walk Test

The Service Walk Test differs from the standard Walk Test. In the standard Walk Test, point expansion modules whose switches are set for a point number not programmed in the control panel **do not** appear in the test. In the Service Walk Test, POPITs whose switches are set for a point number that is not programmed in the control panel **do** appear in the test.

The Service Walk Test allows a user to walk test all 246 points from a control-panel-wide keypad, regardless of the point index type.

A Service Walk Test can also be initiated by account-wide or area-wide keypads but test only those points that are within the scope of the keypad that initiated the function. The Service Walk Test does not test points in armed areas.



Only Walk Test Start and Walk Test End are reported to the central station.



The D9131A can be configured for local printing. Refer to the *D9412GV4/D7412GV4/D7212GV4 Program Entry Guide* (P/N: F01U218312).



During a Service Walk Test, the summary alarm and summary fire remain off, because there are no Fire or Burg alarm conditions to summarize. The P# Relay Response Type feature operates as programmed.

Service Walk Test Procedure

Refer to *Figure 5* on page 23 for Service Walk Test options. Refer to the Walk Test procedures in the *D9412GV4/D7412GV4/D7212GV4 Owner's Manual Supplement* (P/N: F01U245224) when using a D1260 or D1260B Keypad.

1. Choose a keypad to conduct the test. Ensure that the display shows the idle disarmed text.
2. Press the [MENU] key to enter the Function List. Press [NEXT] repeatedly until the SERVICE WALK ? prompt appears.
3. Press [ENT], or press [9][9] followed by [ENT] to reach the Service Menu to access the Service Walk Test.



The D7412GV4 and D7212GV4 **do not** include the Service Walk Test in the Service Menu. To enable the Service Walk Test function for any GV4 Series Control Panel, add its function code to the Function List of a keypad.

4. The display shows ### PTS TO TEST .Test the first detection device.
5. When a detection device is faulted, the keypad emits a brief tone and displays the point text of the point tested for 60 sec. After 60 sec, the display returns to the ### PTS TO TEST message.

Extra Points display default text: If the switches on a POPIT are set incorrectly to a point number that is not in the program for the control panel, the default text for that point number (PT ###) appears when the point is faulted. Refer to the control panel's program record sheet for the default text for all points.

Faulting the point a second time produces the tone and shows the point text, but does not decrease the count in the ## PTS TO TEST message.

To see the points that remain untested during the Service Walk Test:

- a. Press [ESC] when point text appears. The display shows ## PTS TO TEST.
- b. Press the [ESC] key. VIEW UNTESTED ? appears.
- c. Press [ENT]. ## PTS UNTESTED appears.

- d. Press [NEXT] to see a list of the points that have not yet been tested. Move through this list by pressing the [NEXT] key.
 - e. To resume the Service Walk Test, press [ESC]. ## PTS UNTESTED appears.
 - f. Press [ESC]. ## PTS TO TEST appears.
 - g. Resume testing points. To end the Service Walk Test, press [ESC] twice.
6. After the last point is tested, 0 PTS TO TEST appears. Press [ESC]. The display shows ALL PTS TESTED briefly before returning to idle text.



The Service Walk Test, when performed on a D7412GV4, cannot display “0 PTS TO TEST” because the D7412GV4 is physically unable to connect to the second POPEX Module (used for Points 129-247).



Automatic time-out returns the system to idle text: If there is no point or keypad activity for 20 min., the Service Walk Test ends automatically. The keypad returns to idle text.

4.11 Tools Menu

The Tools Menu is collection of configuration and diagnostic functions that can help resolve various installation and operation issues with the GV4 Series Control Panels. The menu is accessed through the Service Menu which is available on any keypad using [9][9][ENTER].

Access to the Tools Menu requires all of the following:

- Service User passcode
- All control panels areas are disarmed
- No unacknowledged alarms
- Only one Tools Menu active at a time
- No active RPS sessions including unattended mode

4.11.1 Programming

Most commonly changed control panel configuration can be viewed and edited through this menu. For a complete list of configuration options refer the GV4 Series Control Panels help files in RPS for details. For a detailed list of configuration prompts and their settings, refer to

the D9412GV4/D7412GV4/D7212GV4 Program Entry Guide (P/N: F01U218312).

4.11.2 Service Bypass

To facilitate system maintenance for service personnel, a special point bypass option is provided through this menu to remove any point from service. The status of points in Service Bypass can be viewed through the View Service Bypass menu in the Service Menu. For details in navigation and operation of this function refer to the *D9412GV4/D7412GV4/D7212GV4 Program Entry Guide* (P/N: F01U218312).

4.11.3 RF Points

With a B820 SDI2 Inovonics Interface Module, the control panels can support up to 350 RF devices and up to eight RF Repeater Modules. The RF Points menu provides the tools necessary to enroll, remove or replace wireless points. For details in navigation and operation of these functions refer to the *D9412GV4/D7412GV4/D7212GV4 Program Entry Guide* (P/N: F01U218312).



The RF Points menu does not affect the RFIDs learned by the D8125INV Wireless Interface Module nor the ISW-D8125CW-V2 Commercial Wireless Interface Module if installed on the Zonex bus.



To enroll, remove or replace user keyfobs refer to the *D9412GV4/D7412GV4/D7212GV4 Owners Manual Supplement* (P/N: F01U245224)

4.11.4 RF Repeaters

With a B820 SDI2 Inovonics Interface Module, the control panels can support up to 350 RF devices and up to eight RF Repeater Modules. The RF Repeaters menu provides the tools necessary to enroll, remove or replace RF Repeaters. For details in navigation and operation of these functions refer to the *D9412GV4/D7412GV4/D7212GV4 Program Entry Guide* (P/N: F01U218312).

4.11.5 RF Diagnostics

With a B820 SDI2 Inovonics Interface Module installed, the control panel can show detailed wireless communication information for RF points, keyfobs and repeaters. The RF Diagnostics menu can show real-time signal strength information for enrolled RF devices. By monitoring the signal strength of an individual RF device, the optimal position for installation can be found.

RF device diagnostic information also includes AC status, battery status, supervision status, and tamper status for all supporting devices. For details in navigation and operation of these functions refer to the *D9412GV4/D7412GV4/D7212GV4 Program Entry Guide* (P/N: F01U218312).

4.11.6 IP Diagnostics

With at least one B420 Ethernet Communication Module installed on the SDI2 bus, the control panels can use the diagnostic functions of this menu to retrieve the auto-configured settings from the module and perform a series of network communication tests. This menu does not apply to the DX4020 modules on the SDI bus.

The **Settings** option retrieves the following from the selected B420 module: Unit Host Name, MAC ID, and current IPV4 Address.

The **Connection Test** option performs the following automated tests for the selected B420 module:

Link	[OK] if Ethernet cable is detected [Missing] if Ethernet cable is not detected.
Gateway	[OK] if an ICMP echo request (PING) response is received from the Gateway Address. [Failure] if response is not received.
Internet	[OK] if an ICMP echo request (PING) response is received from the IP Test Address. [Failure] if response is not received.

Refer to the *D9412GV4/D7412GV4/D7212GV4 Program Entry Guide* (P/N: F01U218312) for details on the B420 Ethernet Communication Module configuration.

Figure 5: Service Walk Test Flow Chart Example

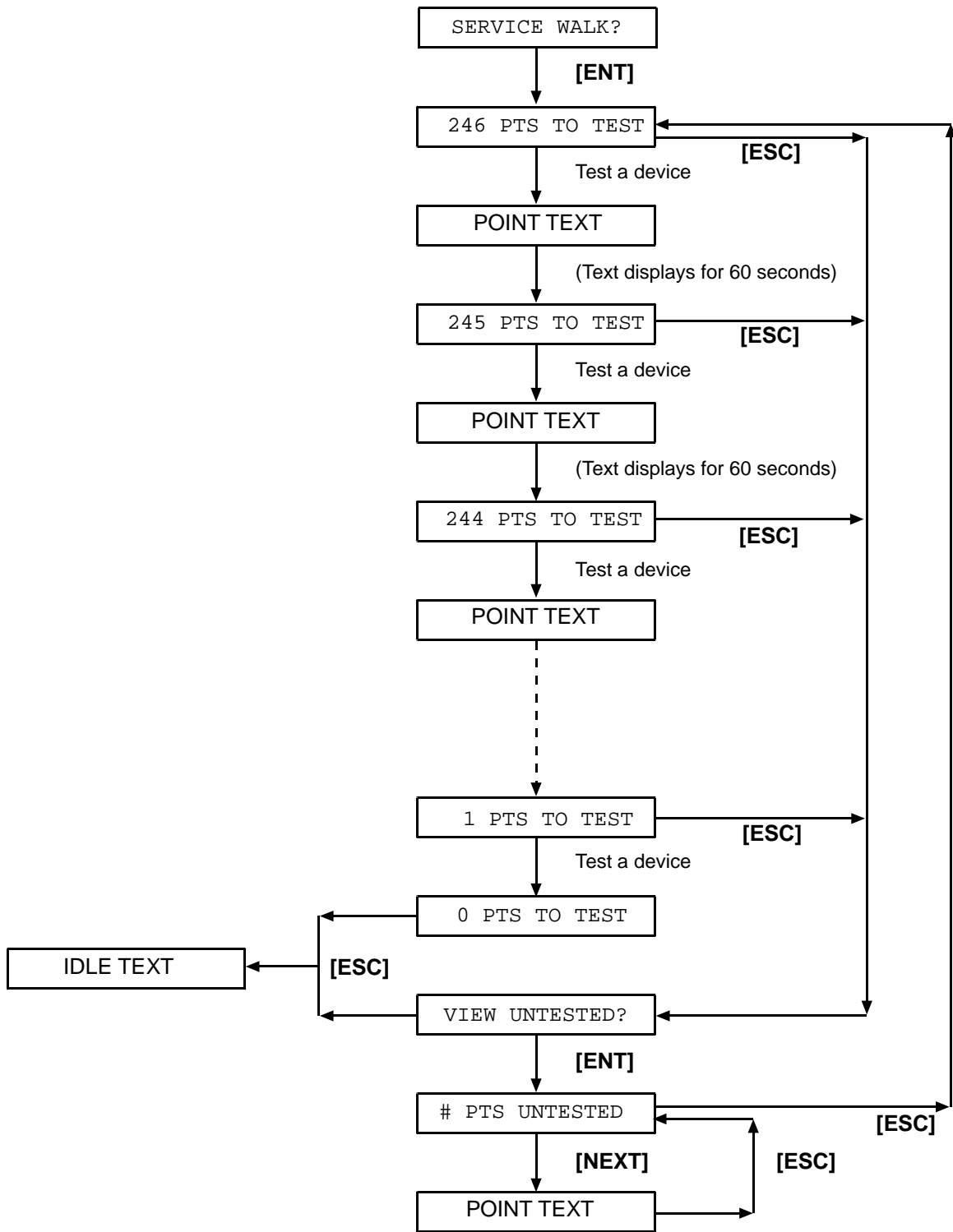

5.0 Power Supply

5.1 Primary Power Terminals 1 and 2

5.1.1 Primary (AC) Power Circuit

The primary source is a 16.5 VAC, 40 VA, internally-fused transformer (Bosch Security Systems, Inc. Model D1640). The control panel draws 200 mA when idle and 300 mA when in an alarm state. The total available auxiliary current is 1.4 A.

Transient suppressors and spark gaps protect the circuit from power surges. This protection relies on the ground connection at Terminal 10. Ensure that you connect Terminal 10 to a proper ground. Refer to *Section 4.5 Connecting Earth Ground* on page 17.

AC Power Fail

The system indicates an AC power failure when Terminals 1 and 2 do not have power. The AC Fail Time parameter sets the number of minutes or seconds without AC power before the control panel acknowledges the failure and the number of minutes or seconds after the power returns before the control panel acknowledges restored power. Refer to the *D9412GV4/D7412GV4/D7212GV4 Program Entry Guide (P/N: F01U218312)* for additional information about AC Fail Time and UL 864 requirements.

5.1.2 Installing the Transformer



Do not short-circuit the terminals of the transformer: Shorting the terminals opens the internal fuse, causing permanent failure. Connect the transformer to Terminals 1 and 2 of the control panel before plugging it into the power source.

1. Use 1.22 mm (18 AWG) wire (minimum) to connect the transformer to the control panel.
The wire length should be as short as possible. The maximum length is 15 m (50 ft). Connect the battery and plug in the transformer.
2. Route telephone and sensor loop wiring away from any AC conductors, including the transformer wire.

AC wiring can induce noise and low level voltage into adjacent wiring. Route data wiring away from AC and telephone wiring.



Always connect the battery first and then plug in the transformer.

3. Connect the battery. Refer to *Section 5.2.2 Installing the Battery* on page 25.
4. Plug the transformer into an unswitched, 120 VAC, 60 Hz power outlet only.
5. Secure the transformer to the outlet with the screw provided.

D8004 Transformer Enclosure Required for Fire Systems

Use the D8004 Transformer Enclosure for the D1640 Transformer in fire and combined fire and burglary applications.



Check with the Authority Having Jurisdiction (AHJ) about mounting transformers on specific circuits.

5.2 Secondary Power Terminals

5.2.1 Secondary (DC) Power

A 12 V sealed lead-acid rechargeable battery (D126) supplies secondary power for auxiliary and alarm outputs, and powers the system during interruptions in primary (AC) power.



Use Lead Acid Batteries Only: The charging circuit is calibrated for lead-acid batteries. Do not use gel-cell or nicad batteries.

Extra Batteries Increase Back-up Time

To increase battery back-up time, connect a second 12 V battery in parallel to the first battery. Use a D122 Dual Battery Harness to ensure proper and safe connection. Refer to the *Standby Battery and Current Rating Chart* in the *D9412GV4/D7412GV4/D7212GV4 Approved Applications Compliance Guide (P/N: F01U201525)* for battery standby time calculations.

D1218 Battery

The D1218 is a 12 V, 18 Ah battery for use in applications requiring extended battery standby time. Up to two D1218 batteries can be connected when used with a D122 Dual Battery Harness.



Caution: When connecting two D1218 Batteries to the control panel, both must have the same capacity (use two 17.2 Ah batteries or two 18 Ah batteries).



When using two D1218 batteries, use a separate enclosure, a D122L Dual Battery Harness, and long leads.

5.2.2 Installing the Battery

1. Place the battery upright in the base of the enclosure.
2. Locate the red and black leads supplied in the literature pack.
3. Connect the black battery lead to Terminal 4, and then to the negative (-) side of the battery.
4. Connect the red battery lead to Terminal 5, and then to the positive (+) side of the battery.



Warning: High current arcs are possible. The positive (red) battery lead and Terminal 5 can create high current arcs if shorted to other terminals or the enclosure. Use caution when working with the positive lead and Terminal 5. Always disconnect the positive (red) lead from the battery before removing it from Terminal 5.



Caution: The battery terminals and wire are **not** power limited. A 6.4 mm (0.250 in.) space must be maintained between the battery terminals, battery wiring, and all other wiring. Battery wiring cannot share the same conduit, conduit fittings, or conduit knock-outs with other wiring.

Figure 6: Battery Terminals

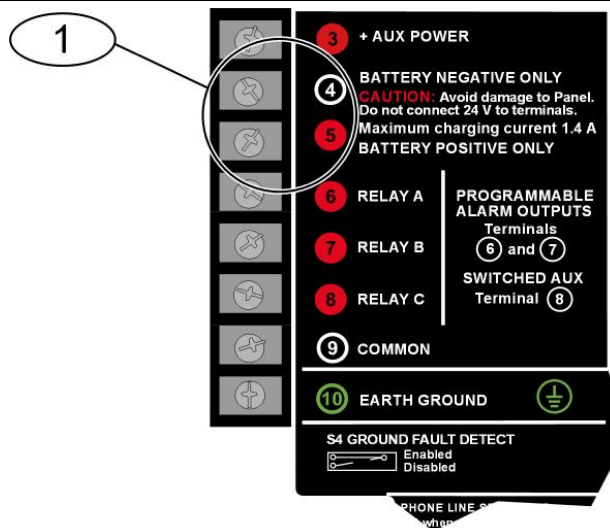

1 - Battery terminals. Terminal 5 is non-power limiting.

Figure 7: Non-Power-Limited Wiring

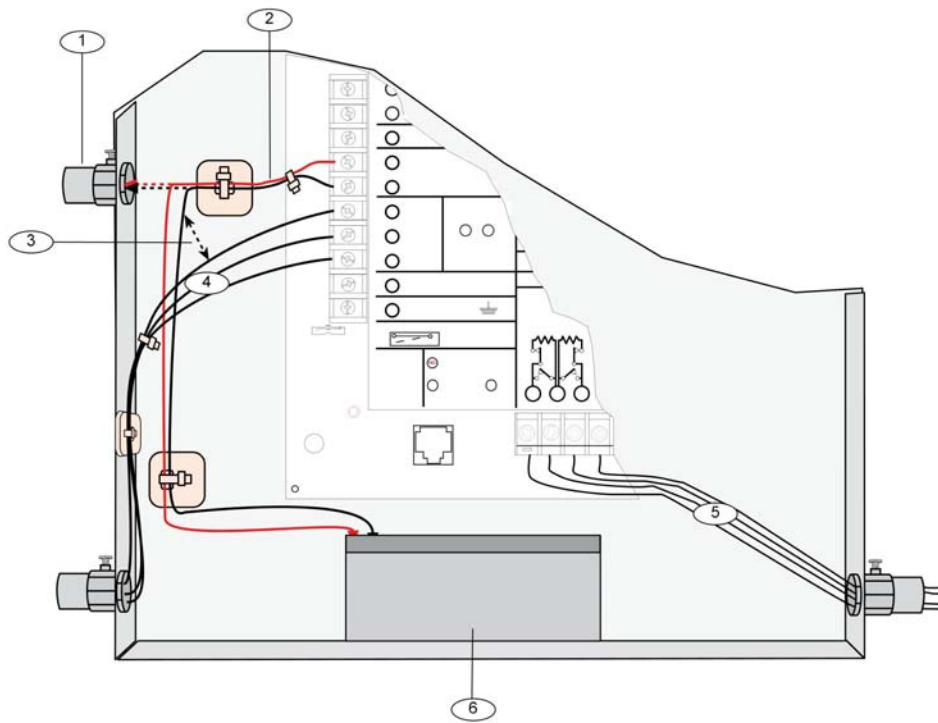

1 - Conduit required for use with external batteries.
 2 - Battery wires
 3 - 6.4 mm (0.25 in.) minimum. To ensure proper spacing, use tie-wraps or similar devices to secure wires.

4 - Relay output wires
 5 - Input or Zone wires
 6 - Standby battery

5.2.3 Replacing the Battery

Replace batteries every 3 to 5 years under normal use. Record the date of installation directly on the battery.



Caution: Exceeding the maximum output ratings or installing the transformer in an outlet that is routinely switched off causes heavy discharges. Routine heavy discharges can lead to premature battery failure.

D8132 Boost Battery Backup: Adding a D8132 Battery Charger Module supports additional batteries of up to 27 Ah capacity, if required.

The control panel, plus any connected D8132 Modules and auxiliary power supplies, must be on the same AC circuit to discharge evenly if AC power fails. The number of D8132 Modules is determined by the number of available outlets on the same circuit. Refer to the *Standby Battery and Current Rating Chart* in the *D9412GV4/D7412GV4/D7212GV4 Approved Applications Compliance Guide* (P/N: F01U201525) for battery standby time calculations.

5.2.4 Battery Supervision

When battery voltage drops to 13.8 VDC, the yellow Charging Status LED illuminates. When the battery voltage drops to 12.0 VDC to 11.8 VDC, the red Low Battery LED lights, and the keypad or keypads display SERVC LOW BATT. The control panel (if programmed for power supervision) sends a BATTERY LOW report in the Modem IIIa² communication format. It sends a Low System Battery (302) report in the Contact ID format.

If the battery is missing or shorted, the red Low Battery LED flashes at the same rate as the green Operation Monitor LED. If the control panel is programmed for power supervision, it sends a BATTERY MISSING report in the Modem IIIa² communication format, or Control Panel Battery Missing (311) report in the Contact ID format.

When battery voltage returns to 13.7 VDC, the Low Battery LED turns off and the keypad or keypads clear the SERVC LOW BATT message. If the control panel is programmed for power supervision, it sends a BATTERY RESTORAL report in the Modem IIIa² communication format or a Control Panel Battery Restored to Normal (302) report in the Contact ID format. At 13.9 VDC, the yellow Charging Status LED stops lighting.

Figure 8: Charging and Battery LEDs

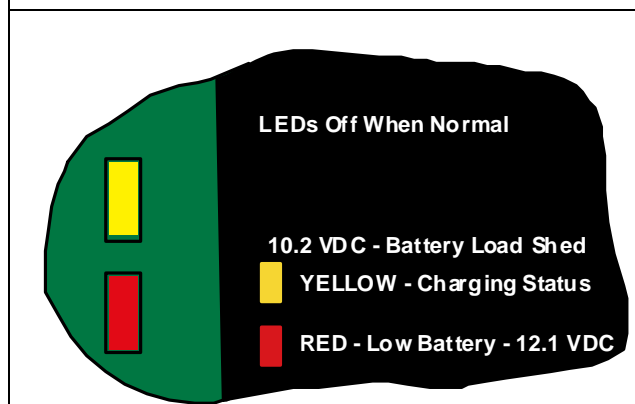

Investigate Low Battery reports immediately: If primary (AC) power is off and the discharge continues, the control panel becomes inoperative when the battery voltage drops below 10.2 VDC.

5.2.5 Battery Charging Circuit

Float Charge

The float voltage for the battery charging circuit is 13.9 VDC at a maximum current of 1.4 A, less any devices connected to the control panel. If the float voltage drops below 13.8 VDC due to overload or battery discharge, the yellow Charging Status LED lights.

Loss of AC Load Shed Relay protects battery:

During an AC power loss, the battery supplies all power to the security system. If the battery voltage falls below 10.0 V during an AC power loss, a load shed relay isolates the battery from the control panel and disables the control panel. Load shed protects the battery from being damaged by deep discharge. When AC power restores, the load shed relay reconnects the charging circuit on the control panel to the battery and the battery begins to recharge.

Overcharge Load Shed With AC Present: If more than 1.4 A of auxiliary current draw from the control panel occurs, the battery supplies the current and begins to discharge. If this situation is not corrected, the battery continues to discharge and at 11.8 VDC to 12.0 VDC, the keypads display Serv Low Batt.

When the battery voltage drops below 10.0 VDC, the control panel shuts down. Remove all loads to the control panel and disconnect AC power. Fix the condition creating the over current. Add a new battery and reconnect AC power.

A shorted battery condition is created either by a shorted cell inside the battery or by a short on Terminals 4 and 5. A shorted battery might cause the control panel to operate in an unsafe way. This condition generates WATCHDOG RESET reports.

Reset the control panel by momentarily placing the reset pin in the disable position. Refer to *Figure 4* on page 18. The red Low Battery LED continues flashing until the control panel resets.

5.2.6 Battery Discharge and Recharge Schedule

Table 6: Battery Discharge and Recharge Schedule	
Discharge Cycle	
AC Off:	AC Fail Report when AC fails, if control panel is programmed to report AC failure at occurrence.
13.9 VDC:	Charging float level.
13.8 VDC:	Charging status LED on.
12.0 VDC:	Low Battery and AC Fail Reports if programmed. Low battery LED on.
<10.0 VDC:	Battery load shed (processing functions continue if AC is present).
Recharge Cycle	
AC On:	Load shed relay reset; battery charging begins; Battery Trouble and AC Restoral Reports sent.
13.7 VDC:	Battery Restoral Reports sent. Low battery LED off.
13.9 VDC:	Changing status LED off; battery float charged.

Table 7: Charging Status and Low Battery LEDs

Type	LED		Action
	Color	State	
Charging Status LED	Yellow		Shows the charging status of the battery. Refer to <i>Figure 8</i> on page 27 for location.
	Yellow	Off	Battery is fully charged. If the battery is missing, shorted, or reversed, the Charging Status LED is off, but the red Low Battery LED is flashing.
	Yellow	On	Battery float charge is below 13.8 VDC. If AC is present, the battery is charging. Indicates the combined current draw from all outputs exceeds 1.4 A. This is normal under alarm conditions for non-fire systems with sirens or bells drawing more than 1.4 A. If the LED lights regularly for extended periods or does not go out, check the current draw for devices connected to the power outputs. Refer to <i>Section 6.0 Power Outputs</i> on page 30 for instructions.
Low Battery LED	Yellow	Flash once per minute	System is checking the battery.
	Red		Shows the condition of the battery. Refer to <i>Figure 8</i> on page 27 for location.
	Red	Off	Battery is fully charged.
	Red	On	Battery voltage dropped to between 12.0 VDC and 11.8 VDC. LED turns off when voltage reaches 13.7 VDC.
	Red	Flash	Battery is missing or shorted.

6.0 Power Outputs

6.1 Circuit Protection

Three self-resetting circuit breakers protect the control panel from short circuits on the continuous and programmable power outputs. If the control panel is programmed for power supervision and a short circuit occurs on one of the power outputs, the control panel sends BATTERY LOW and BATTERY MISSING when using Bosch Security Systems, Inc. Modem IIIa² communicator format. Under the same conditions when using Contact ID communicator format, the control panel sends Control Panel Battery Low (302) and Control Panel Battery Missing (311).

One self-resetting circuit breaker protects:

- Terminal 3: Auxiliary Power
- Terminal 24: Zonex Power



A short circuit on one terminal disrupts power to the other terminal.

Another self-resetting circuit breaker protects:

- Terminal 6: Alarm Power Output
- Terminal 7: Alternate Alarm Power Output
- Terminal 8: Switched Auxiliary Power.



A short circuit on one of the terminals disrupts power to the other two terminals.

The third self-resetting circuit breaker protects Terminal 32: Power +.



UL requires any device powered from a power output to be supervised.



UL requires that power outputs are not shared between fire and non-fire devices unless all devices are in conduit within 20 ft and are in the same room.

6.2 Total Available Power

The system produces up to 1.4 A of combined power at 12.0 VDC nominal for special application use. The outputs listed below share the available power. These outputs are shown as red circles on the faceplate.

Terminal 3 - Auxiliary Power: Use this terminal to power devices requiring continuous power.

Terminal 6 (Relay A) - Alarm Power Output: Programmable relay normally open, power on alarm.

Terminal 7 (Relay B) - Alternate Alarm Power Output: Programmable relay normally open, power on alarm.

Terminal 8 (Relay C) - Switched Auxiliary Power: Programmable relay normally closed, switches power off when the Sensor Reset command is executed.

Terminal 24 - Zonex Power: Use this terminal to power Zonex modules such as the D8125, D8128D, and D8129 Modules.

Terminal 32 – SDI Power +: Use this terminal to power serial device interface (SDI) devices such as keypads, the D9131A Parallel Printer Interface Modules, or the D9210C Access Control Interface Modules.

Terminal 36 – SDI2 Power +: Use this terminal to power serial device interface (SDI2) devices such as the B208 Octo-input Module, the B308 Octo-output Module, the B420 Ethernet Communication Module, and the B820 Inovonics Interface Module.

Accessory Connector: The D928 Dual Phone Line Switcher connects to the accessory connector.

6.3 Continuous Power Output Terminals 3, 8, 24, and 32

The continuous current draw for powered devices connected to Terminals 3, 8, 24, and 32, and the accessory connector must not exceed 1.4 A. Devices powered from these outputs operate at 12.0 VDC Nominal.

Power Restricted for Fire and Combined Fire and Burglary Systems: Use the Fire System Power Formula to calculate the current available for fire and combined fire and burglary systems (refer to *Section 6.4 Programmable Power Output Terminals 6, 7, and 8*).

6.4 Programmable Power Output Terminals 6, 7, and 8

6.4.1 Programming

The power outputs at Terminals 6, 7, and 8 are programmed as Relays A, B, and C. All relays are programmed in the Relays section.

Relays are assigned a relay type, (Fire Bell, for example) when they are assigned to an area. Relays can be assigned to one or more areas.

The Bosch Security Systems, Inc. defaults set Relay A (Terminal 6) as a Steady Alarm Bell output, Relay B (Terminal 7) as a Pulsed Fire Bell output, and Relay C (Terminal 8) as a Verification or Reset output for smoke detectors. The *D9412GV4/D7412GV4/D7212GV4 Program Entry Guide (P/N: F01U218312)* contains complete instructions for programming relays. Refer to *Sections 6.4.2 Terminals 6 and 7, 6.4.3 Fire System Power Formula, and 6.4.4 Terminal 8* on page 31 for descriptions of the functions of each terminal.

Refer to the Bell Parameters section of the program to set the Fire Bell, Alarm Bell output responses for relays. Four annunciation patterns are available: Steady, Pulsed, California Standard, and Temporal Code 3.

Voltage Output at Terminals 6, 7, and 8

If Terminals 6, 7, and 8 do not provide the expected output, check:

- Programming for Relays A, B, and C in the relays section of the program.
- Bell Parameters section of the program to confirm that the Alarm and Fire Bell responses are programmed for the expected duration and pattern.
- Point Assignments section to confirm that each point is programmed for the expected local response.

6.4.2 Terminals 6 and 7

When activated, Terminals 6 (Relay A) and 7 (Relay B), provide positive (+) 12.0 VDC Nominal power output. Use the power at Terminals 6 and 7 to power bells, siren drivers, piezoelectric fire sounders, electronic horns, or other devices.

Programming determines the format of the output and the conditions that activate it. One self-resetting circuit breaker protects Terminals 6, 7, and 8 against shorts. When using Relay A or Relay B to activate notification appliance circuits in UL Listed fire alarm applications, install a D192G Indicating Circuit Module.

Power Restricted for Fire and Combined Fire and Burglary Systems: Fire systems are prohibited from using the battery for determining alarm power. Use the fire system power formula that follows to calculate the current available for fire and combined fire and burglary systems.

6.4.3 Fire System Power Formula

To calculate the current available at Terminals 6 and 7 for fire and combined fire and burglary systems:

1. Add together the current draws for all devices connected to Terminals 3, 8, 24, and 32, and the accessory connector. This is the total current required for the normal standby condition (NSC).
2. The current available for NSC is 1.4 A. Subtract the NSC current required calculated in *Step 1* from the NSC current available, 1.4 A. The difference is the alarm current available for Terminals 6 and 7.

In formula format:

$$1.4 \text{ A} - \text{NSC current required (Step 1)} = \text{Alarm current available}$$

Refer to the *D9412GV4/D7412GV4/D7212GV4 Approved Applications Compliance Guide (P/N: F01U201525)* for module or accessory current requirements.

6.4.4 Terminal 8

Terminal 8 provides continuous positive (+) 12.0 VDC Nominal power. Relay C interrupts the power at Terminal 8 when activated. Use Terminal 8 to power smoke detectors or other devices that are reset by interrupting power. One self-resetting circuit breaker protects Terminals 6, 7, and 8 against shorts.

Verification and Reset Relay

The default program sets Relay C (Terminal 8) as a verification and reset relay. Refer to *Relay Parameters and Point Assignments* in the *D9412GV4/D7412GV4/D7212GV4 Program Entry Guide (P/N: F01U218312)* for instructions on programming verification and reset relays and points.

Performing a sensor reset at a keypad produces a five-sec relay activation of verification and reset relays. The control panel ignores verification and resettable points during the five sec.

7.9 Called Party Disconnect

Telephone companies provide “called party disconnect” to allow the called party to terminate a call. The called party must go on hook (hang up) for a fixed interval before a dial tone is available for a new call. This interval varies with telephone company equipment. Control panel firmware allows for “called party disconnect” by adding a 35-sec, “on hook” interval to the dial tone detect function. If the control panel does not detect a dial tone in 7 sec, it puts the telephone line on hook for 35 sec to activate “called party disconnect,” goes off hook, and begins a seven-second dial tone detect. If no dial tone is detected, the control panel dials the number anyway. Each time the number is dialed, the control panel records this as an attempt.

7.10 Communication Failure

If a backup route is configured and the first two attempts to reach the receiver over the phone line fail, the system switches to the backup route. When it switches to the backup route, a COMM TROUBLE PH # event is sent, and the event that triggered the telephone call to the central station follows.

After ten unsuccessful attempts to reach the receiver, the control panel enters communication failure. The control panel clears any reports queued for the failed route and a COMM FAIL # event is generated and display at the keypads. A trouble sounder can be programmed to annunciate at the keypads.

One hour after the COMM FAIL # is generated, the control panel attempts to send a restoration event. If a communication failure still occurs, the keypad trouble sounds again.

If the D928 Dual Phone Line Switcher is used, the control panel makes a total of ten attempts before entering communication failure.

Enhanced Communication

The control panels can send events over the SDI Bus through a DX4020 Network Interface Module (NIM) or over the SDI2 bus through a B420 NIM. For more information on the enhanced communications capabilities, refer to the *D9412GV4/D7412GV4/D7212GV4 Program Entry Guide (P/N: F01U218312)*.

7.11 D928 Dual Phone Line Switcher

7.11.1 Description

The optional D928 Dual Phone Line Switcher allows the D9412GV4 and D7412GV4 Control Panels to send reports over two separate telephone lines. If a telephone line is not within the operating range, the control panel attempts to use the other telephone line to send the message. If trouble is detected, the control panel keeps the faulty telephone line in memory.

Set the Ring Count above 2 on Answering

Machines: The control panel’s RPS line monitor feature might not operate correctly if an answering machine with a ring count of less than two rings is connected to a telephone line used by the D928 Module.

7.11.2 Operation

Refer to *Phone* and *Phone Parameters* section of the *D9412GV4/D7412GV4/D7212GV4 Program Entry Guide (P/N: F01U218312)* for telephone supervision and reporting options. To use the D928, set the **Two Phone Lines** prompt to **Yes**.

When the D928 is installed, the control panel alternates between Phone Line 1 and Phone Line 2 to send its first report. For example, on day one, the control panel first attempts to communicate on Phone Line 1. On day two, the control panel switches and attempts to communicate on Phone Line 2.



Any time the control panel resets or is powered down or up, the next reported event always attempts to call out on Phone Line 1 first.



If Phone Line 2 is not in service on “Day 2”, the control panel switches to the primary phone line to send the report.

With the D928 Dual Phone Line Switcher installed, the control panel uses two telephone lines (primary and secondary) to dial up to four telephone numbers.

When using a primary and a backup device within a **Route Group #**, the control panel makes two attempts on the primary telephone line using the **Primary Device #** as programmed. If these two attempts fail, the control panel switches to the secondary telephone line using the **Backup Device #** as programmed. This pattern continues for a total of ten attempts. After ten unsuccessful attempts, the control panel generates a Comm Fail event for the given **Route Group #**.

Figure 11: D928 Dual Phone Line Switcher

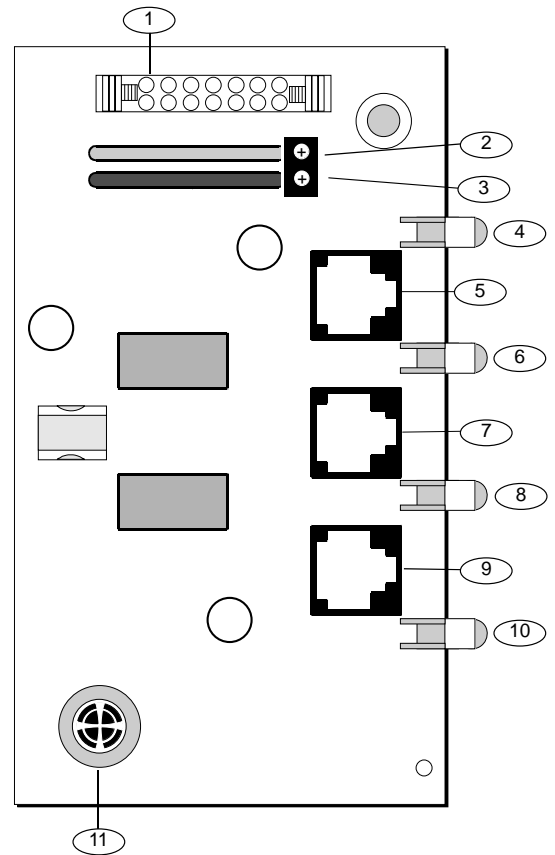

- 1 - Connect to ACCESSORY CONNECTOR with ribbon cable.
- 2 - Green to Terminal 1
- 3 - Black to Terminal 9
- 4 - AC Power LED (green)
- 5 - Phone jack to primary phone line
- 6 - Primary Fail LED (yellow)
- 7 - Phone jack to secondary phone line
- 8 - Secondary Fail LED (yellow)
- 9 - Phone jack to telco connector
- 10 - Communications Fail LED (yellow)
- 11 - Buzzer

7.11.3 Installing the D928

Mounting

Mount the D928 on the lower right side of the enclosure using the screws provided with the switcher.

Wiring

The D928 has two flying leads. The green lead monitors AC power. The black lead is the ground reference for the AC Power LED.

1. Connect the green lead from the D928 to Terminal 1.
2. Connect the black lead from the D928 to Terminal 9.

Telephone Connections

1. Plug one end of the ribbon cable provided into J4 on the D928. Plug the other end of the ribbon cable into the ACCESSORY connector on the control panel.
2. Plug one end of the D162 phone cord provided into the telco jack. Plug the other end of the phone cord into the TELCO jack on the control panel. Refer to *Table 8* for phone cord lengths.

Phone Cord	Length
D161	2.4 m (8 ft)
D162	61 cm (2 ft)

3. Plug one end of a D161 or D162 phone cord into J1 on the control panel. Plug the other end of the phone cord into the RJ31X or RJ138X for the primary telephone line.
4. Plug one end of a D161 or D162 phone cord into J2 on the control panel. Plug the other end of the phone cord into the RJ31X or RJ138X for the secondary telephone line. Refer *Table 8* for phone cord lengths.

7.11.4 D928 Status LEDs

Four LEDs mounted on the front edge of the D928 Module show the status of AC power for the control panel, the status of the two telephone lines, and communication failure (*Figure 11* on page 34). When programmed and operating normally, only the green AC power status LED is lit.

AC Power LED

The green AC Power Status LED lights when AC power is applied to Terminals 1 and 2 on the control panel.

Phone Line Fail LEDs

Two yellow Phone Line Status LEDs (one for the primary telephone line, one for the secondary telephone line) light if the telephone line is not within the operating range. The control panel monitors the faulty telephone line for the programmed interval before indicating a trouble condition. Refer to *Section 7.8 Telephone Line Monitor* on page 33 for a description of phone line monitor operation.

Communication Failure LED

The yellow Communication Failure LED lights when the system is in communication failure. The LED turns off when communication restores. Refer to *Section 7.10 Communication Failure* on page 34.



Dedicated telephone lines might be required for UL 864 Commercial Fire applications. Check with your Authority Having Jurisdiction (AHJ).

8.0 On-Board Points

8.1 Terminals 11 to 22 Description

The control panel provides eight on-board points. Each point functions independently and does not interfere with the operation of the others. The control panel monitors the sensor loops for normal, shorted, or open conditions between an input terminal (11, 13, 14, 16, 17, 19, 20, or 22) and any of the point common terminals (12, 15, 18, and 21). The programming for the point determines how the control panel responds to those conditions. Refer to the *D9412GV4/D7412GV4/D7212GV4 Program Entry Guide (P/N: F01U218312)* for point programming options. The control panel also monitors the sensor loops for ground fault conditions if S4 is latched (ground fault detect enabled).

8.2 Point Sensor Loops



Not for use in Fire Applications.

When wiring the on-board points (*Figure 12*), install a 1 kΩ resistor at the far end of the sensor loop to provide a reference for supervision. Dry-contact sensing devices can be connected in series (normally-closed) or in parallel (normally-open) to any of these loops.

The number of normally-open and normally-closed detection devices each sensor loop can supervise is limited only by the resistance on the loop. The total resistance for the wire length and contacts, minus the end-of-line (EOL) resistor, must not exceed 100 Ω.

8.3 Point Parameters

The condition of on-board Points 1 to 8 is determined by measuring the voltage across the point input terminal and one of the common terminals. The sensor loops must be connected and the 1 kΩ EOL resistor in place.

Table 9: Point Parameters

Loop	Voltage Range
Open	Greater than 3.7 VDC, but less than 5.0 VDC.
Normal	Greater than 2.0 VDC, but less than 3.0 VDC.
Shorted	Greater than 0.0 VDC, but less than 1.3 VDC.

Figure 12: On-board Point Sensor Loop Wiring

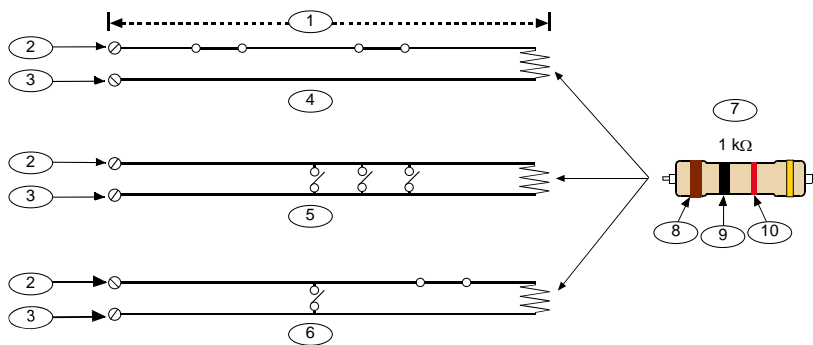

1 - 100 Ω maximum

2 - Point input terminal

3 - Common

4 - Normally-closed contacts (NC)*

5 - Normally-open contacts (NO)

6 - Combination: Normally-open contacts and normally-closed contacts (NO/NC)

7 - P105F (Package of 8 EOL resistors) or P105BL (Package of 8 UL Listed EOL resistors) (P/N: 15093130-004)

8 - Brown

9 - Black

10 - Red

* UL does not allow normally-closed loops for commercial fire applications.

8.4 Point Response Time

The control panel scans on-board and off-board point sensor loops every 300 ms. The Debounce program item in the Point Assignment section of the software determines point response time by setting the number of times the control panel scans a point before generating an alarm.

The debounce count can range from 2 to 15; therefore, point response time ranges from 600 ms to 4.5 sec. The Bosch Security Systems, Inc. default for debounce count is 2.



Increasing debounce might cause missed alarms. If you increase the debounce count, detection devices can enter alarm and reset without exceeding the point response time.

Use a debounce count of 2 for all points **except**:

- Use 3 for Interior Follower points.
- Use 4 for door points connected to a D9210C Access Control Interface Module.

8.5 Wiring Information for Installations Using the Rothenbuhler 5110/4001-42 High Security Bell



Warning: Wear ear protection when installing and testing the Rothenbuhler High Security Bell.

Sound levels greater than 95 dBA at 3 m (10 ft) can occur.

5. Wire the 4001-42 to the control panel. Refer to *Figure 13* on page 39 and the Rothenbuhler installation manual.
6. Before supplying AC and DC power to the control panel and bell, ensure you are wearing ear protection. The bell sounds for 2 sec and then silences during power up.

For additional information about bell requirements, refer to *Bank Safe and Vault Applications* in the *D9412GV4/D7412GV4/D7212GV4 Approved Applications Compliance Guide* (P/N: F01U201525).

1. Remove all power from the control panel.
2. Use six-conductor 1.2 mm (18 AWG) shielded stranded wire between the control panel and the 5110 Logic Board (located in the bell enclosure).
3. If you do not have a Silence switch, temporarily install a 1 Ω resistor across TB1-1 and TB1-6 on the 5110 Logic Board. The resistor keeps the 5110's bell silent during the installation and alignment procedures. Also place a temporary wire jumper across the TB1-6 Bell Relay and TB1-7. Refer to *Figure 13* on page 39 for wiring a Silence switch.
4. Mount the D8108A's 4001-42 External Balanced Line Module and wire it to the 5110 Logic Board using two-conductor 0.8 mm (22 AWG) cable.

Figure 13: Wiring the Rothenbuhler 5110/4001-42 High Security Bell to the Control Panel

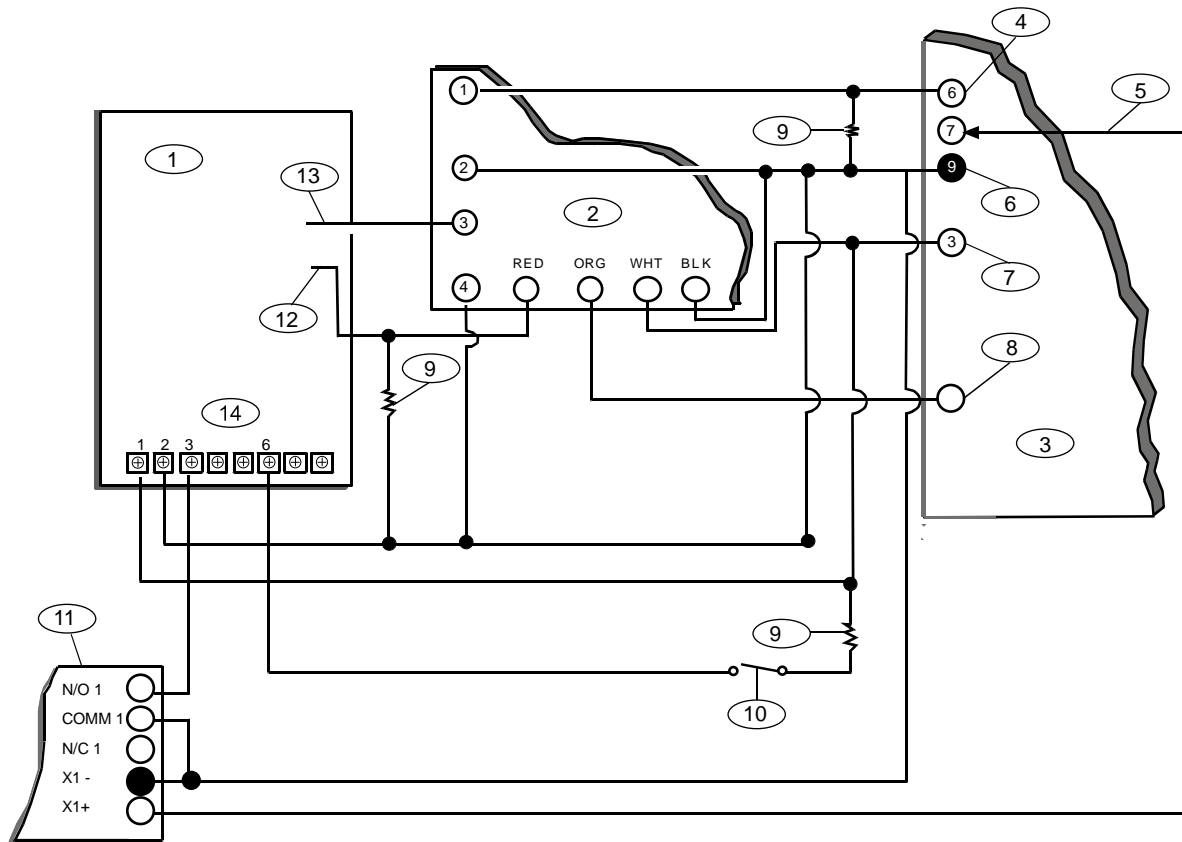

- 1 - 5110 Logic Board
- 2 - 4001-42 External Line Balancing Module
- 3 - D9412GV4 or D7412GV4 Control Panel
- 4 - Alarm output
- 5 - Alternate alarm
- 6 - Common
- 7 - +12.0 VDC

- 8 - Alarm zone input*
- 9 - 10 kΩ resistor
- 10 - Optional Silence switch
- 11 - D133 Relay Module
- 12 - BBL In 4
- 13 - BBL Out 5
- 14 - Terminal TB1

* Use Terminal 11, 13, 14, 17, 19, 20, or 22. (select only one.)

9.0 Off-Board Points

9.1 Zonex Buses

9.1.1 POPIT Modules

The D9412GV4 can use point of protection input transponder (POPIT) modules to provide a maximum of 238 off-board points, bringing the total number of points the D9412GV4 can monitor to 246. The D7412GV4 provides up to 67 off-board points, bringing the total number of points the D7412GV4 monitors to 75. The D7212GV4 can use point of protection input transponder (POPIT) modules to provide a maximum of 32 off-board points, bringing the total number of points the D7212GV4 can monitor to 40. Each off-board point requires a POPIT Module.



The expansion bus can be shared between fire and non-fire devices where the POPIT module provides data isolation between the input and the bus connections.

9.1.2 POPEX Modules

POPITs connect to supervised two-wire data expansion loops run from POPIT to POPIT throughout the premises. Data expansion loops connect to a D8125 Point of Protection Expander (POPEX) Module. POPEX Modules have power and data connections to the point bus on the control panel (*Table 10*).

Table 10: POPEX Modules

Model	Power	Data
D9412GV4	Terminals 23 and 24	Terminals 25 and 26 or Terminals 27 and 28
D7412GV4 , D7212GV4	Terminals 23 and 24	Terminals 27 and 28

9.1.3 Missing Conditions

If a programmed POPIT is disconnected from the expansion loop, a missing condition appears immediately and the event is logged. The missing condition might also be sent to a central station or printed to an on-site printer, if programmed to do so. Refer to the *D9412GV4/D7412GV4/D7212GV4 Program Entry Guide (P/N: F01U218312)* for programming options.

9.1.4 Control Panel Responses to Missing Point Conditions

The D9412GV4, D7412GV4 and D7212GV4 respond to missing point conditions based on the point's programming and the armed state of the point's area. For example, if an interior motion detector point is missing during a disarmed state, a Missing Trouble event is generated; however, if the point is missing while the area is Master Armed, a Missing Alarm event is generated. Non-fire, 24-hour points always generate a Missing Alarm event, whereas Fire points always generate a Missing Fire Trouble event.

9.2 D8125 and D9127 POPIT Modules

D9127 POPITs use the D8125 POPEX Module to report to the control panel. Each D8125 supports up to 119 POPIT points. Connect two D8125 Modules to the D9412GV4 to bring the combined total number of POPIT and on-board points to 246.

- Points 9 to 127 connect to the first POPEX Module.
- Points 129 to 247 connect to the second POPEX Module.
- The D9412GV4 reserves Points 128 and 248 for internal use.

The control panel annunciates activity only for each POPIT, not for each detection device connected to the sensor loop.

The D9127 Module enclosures are made of UL Listed fire resistant material. D9127T Modules contain tamper switches. D9127U Modules include untampered covers. Unless the module is mounted in a tampered enclosure, UL requires D9127T Modules for certificated accounts.

Listings

The D8125 POPEX and the D9127 POPIT Modules are UL Listed for Local or Police Connected Burglar Alarm, Central Station Burglar Alarm, Household Burglar Alarm, Central Station Fire, Local Fire, Remote Station Fire, Household Fire, and Electrically Actuated Transmitter Applications.

Refer to the *D9412GV4/D7412GV4/D7212GV4 Approved Applications Compliance Guide* (P/N: F01U201525) to determine the required equipment and enclosures for the application.

Figure 14: Connecting the D8125 POPEX to the D9412GV4 Control Panel

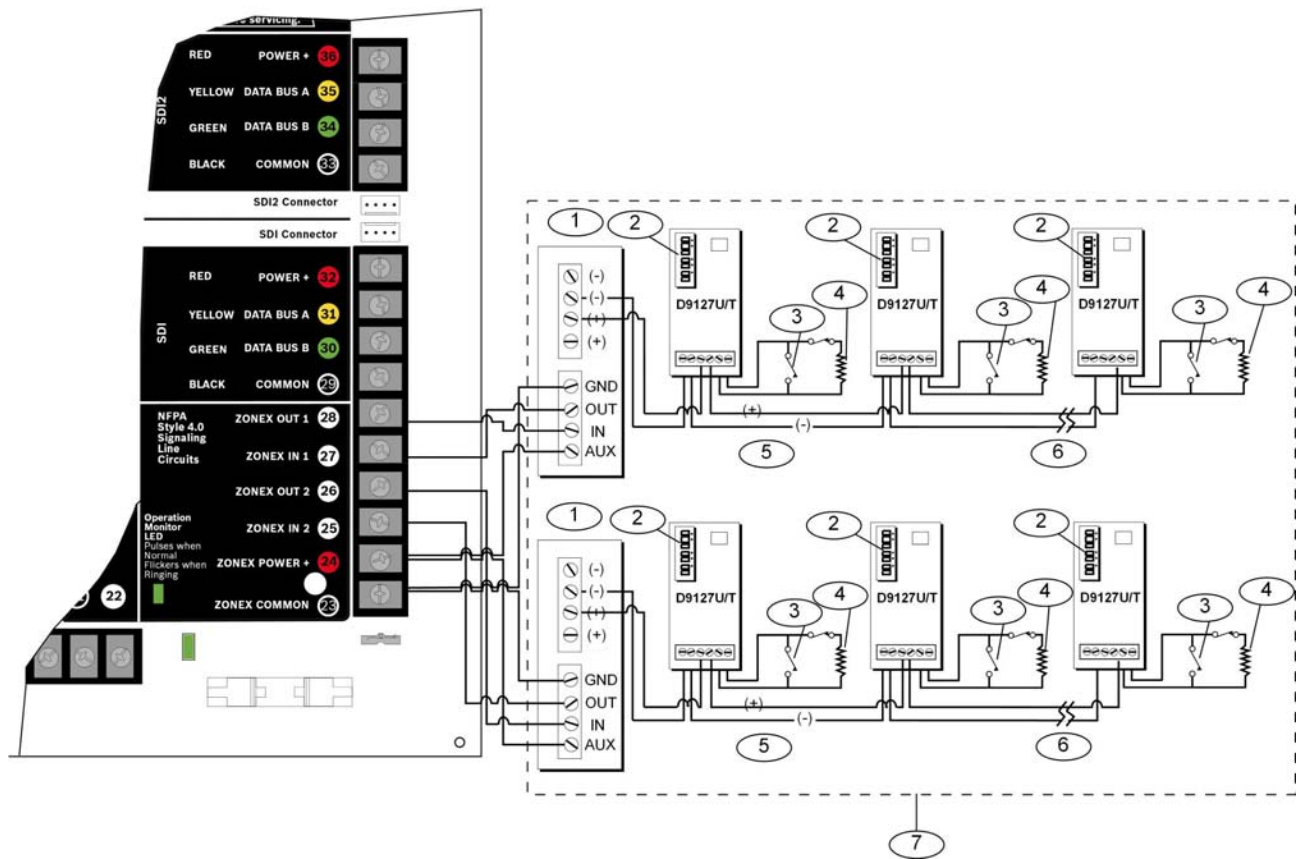

- | | |
|--|-------------------------|
| 1 - D8125 POPEX Module | 5 - Zone expansion loop |
| 2 - Switch block | 6 - Up to 119 POPITs |
| 3 - D9127 Sensor Loop | 7 - Expansion zones |
| 4 - 33 kΩ EOL resistor (P/N: P106F [15-03130-002], package of eight) | |



For system supervision, do not use looped wire terminals. Break the wire run to provide supervision of the connections.

Figure 15: Connecting the D8125 POPEX to the D7412GV4 and D7212GV4 Control Panels

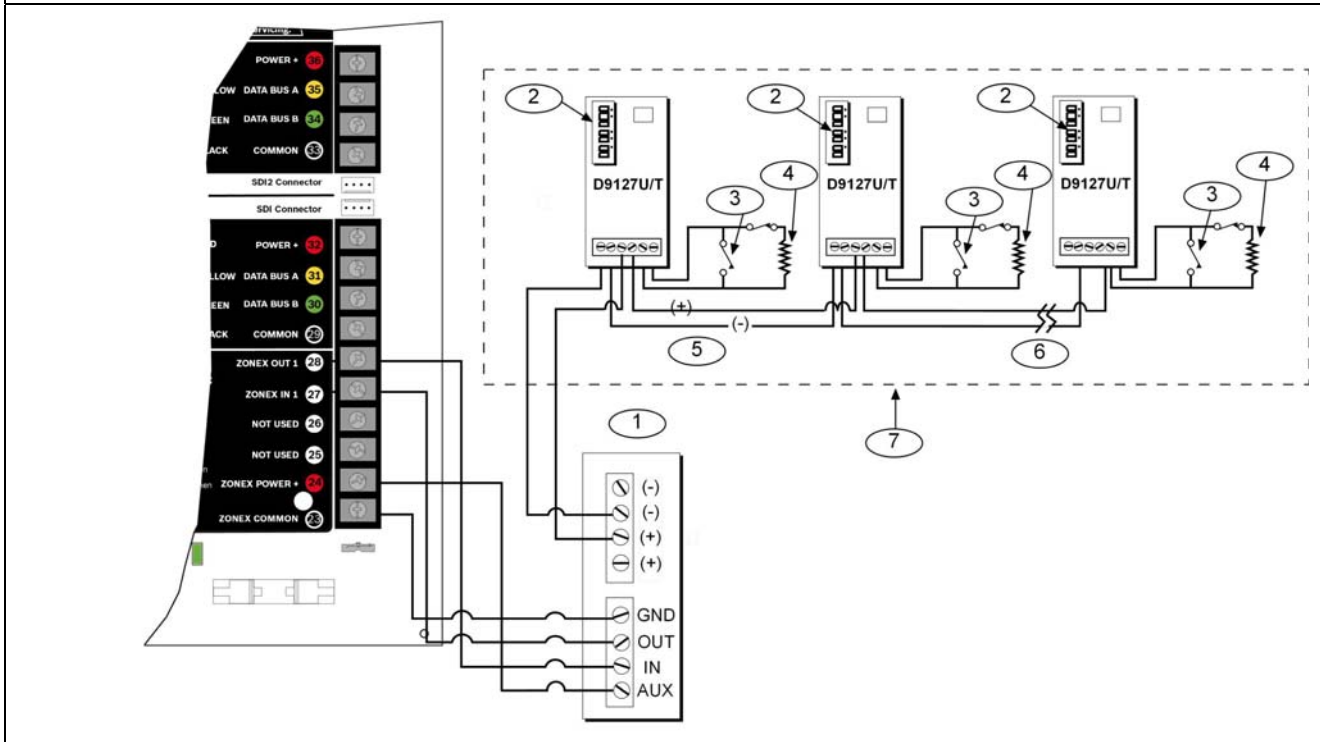

- | | |
|--|-------------------------|
| 1 - D8125 POPEX Module | 5 - Zone expansion loop |
| 2 - Switch block | 6 - Up to 119 POPITs |
| 3 - D9127 Sensor Loop | 7 - Expansion zones |
| 4 - 33 kΩ EOL resistor (P/N: P106F [15-03130-002], package of eight) | |



For system supervision, do not use looped wire terminals. Break the wire run to provide supervision of the connections.

9.3 Installing the D8125 POPEX Module



For information on the Multiplex Bus Interface, refer to the *D8125MUX Multiplex Bus Interface Operation and Installation Guide* (P/N: F01U034973).

Save the POPIT Label Sheets: The D8125 is packaged with two sets of POPIT label sheets. One set is marked “Bank 1” for use with the D7412GV4 and D7212GV4. The other set is marked “Bank 2” for use with the D9412GV4 and D9112. Use the sheets later to label the POPITs. Refer to *Section 9.3.6 POPIT Module Point Assignments* on page 45.

9.3.1 Mounting

To install the D8125 in the enclosure with the control panel:

1. Align the D8125 POPEX Module with any of the four mounting locations in the enclosure (*Figure 2* on page 16).
2. Using the screws provided with the module, secure it in the enclosure.

9.3.2 Wiring the D8125 to the Control Panel

To wire one or two D8125 Modules to the control panel (*Figure 14* on page 42 or *Figure 15* on page 43):

Power Down the Control Panel: Disconnect the positive (red) battery lead at the battery and unplug the transformer.

For Points 9 to 127 (9 to 75 on D7412GV4):

1. Connect the GND terminal of the D8125 to Terminal 23 on the D9412GV4 or to Terminal 9 on the D7412GV4.
2. Connect the OUT terminal of the D8125 POPEX Module to ZONEX IN 1, Terminal 27.
3. Connect the IN terminal of the D8125 POPEX Module to ZONEX OUT 1, Terminal 28.
4. Connect the AUX terminal of the D8125 to Terminal 24 on the D9412GV4 or to Terminal 3 on the D7412GV4.

For Points 129 to 247 (D9412GV4 only):

1. Connect the GND terminal of the D8125 to Terminal 23.
2. Connect the OUT terminal of the D8125 POPEX Module to ZONEX IN 2, Terminal 25.
3. Connect the IN terminal of the D8125 POPEX Module to ZONEX OUT 2, Terminal 26.
4. Connect the AUX terminal of the D8125 to Terminal 24.

Refer to *Section 9.3.4 Wiring Data Expansion Loops to POPEX Modules* on page 44 for instructions on connecting POPITs to the D8125 POPEX Module.

9.3.3 Wiring POPITs to the Data Expansion Loop

Use one two-wire data expansion loop or distribute the POPITs on up to three loops. Setting DIP switches on the POPIT Modules assigns them to point numbers. Refer to *Section 9.3.6 POPIT Module Point Assignments* on page 45.

Review *Section 4.6.2 Installing and Wiring Detection Devices* on page 19 to determine if shielded wire is required. Refer to *Table 11* to determine the wire gauge for the length of each data expansion loop.

Table 11: Data Expansion Loop Wire Specifications	
Maximum Length of All Data Expansion Loops Combined	
AWG	Length in Meters (Feet)

22	548 (1800)
20	881 (2890)
18	1402 (4600)
16	2231 (7320)
14	3551 (11,650)

Combine Data Expansion Loops

The maximum lengths shown in *Table 11* are for all data expansion loops connected to the same POPEX Module combined.

Wiring POPITs Together

 Do not connect POPITs to each other in series or with a T-tap. Doing so might cause random missing POPIT conditions.

 Before installing the POPITs, ensure that the resistance on the data expansion loop is no more than 40 Ω.

To connect POPITs to one another in parallel:

1. Connect the positive (+) data terminal from one POPIT to the positive (+) data terminal on the next POPIT.
2. Connect the negative (-) data terminal from one POPIT to the negative (-) data terminal on the next POPIT.
3. Repeat Steps 1 and 2 to connect all POPITs to the expansion loop. It is not necessary to wire the POPITs in any particular order on the loop. The switch setting on each POPIT assigns it a point number, regardless of its physical location.

Three-inch Clearance for Tamped POPITs

Mount tamped POPIT modules at least 7.6 cm (3 in.) apart to prevent the tamper magnets from interfering with each other.

9.3.4 Wiring Data Expansion Loops to POPEX Modules

Each POPEX Module has two positive (+) and two negative (-) data expansion loop terminals. Up to 119 POPITs can be connected to one D8125 on the D9412GV4; up to 67 POPITs for the D7412GV4 (*Figure 14* on page 42 or *Figure 15* on page 43).

To connect the data expansion loops to the D8125 POPEX Module:

1. Connect the positive (+) data terminal from the first POPIT on the data expansion loop to one of the D8125's positive (+) terminals.

2. Connect the negative (-) data terminal from the first POPIT on the data expansion loop to one of the D8125's negative (-) terminals.

9.3.5 POPIT Sensor Loops

The number of normally-open and normally-closed detection devices each sensor loop can supervise is limited only by the resistance on the loop. Resistance on each sensor loop must be less than 100 Ω , not including the EOL resistor.



Certain UL and NFPA applications can limit the number of detection devices. Consult the appropriate UL or NFPA standards.

POPITs detect open, shorted, normal, and grounded circuit conditions on their sensor loops. They send the condition of their loops to the control panel. A ground on the sensor loop sends a general system ground-fault condition report. Each POPIT is programmed and sends signals to the control panel separately.

Terminate each POPIT sensor loop with the 33 k Ω end-of-line (EOL) resistor (D106F) included with each POPIT.

Use a twisted-pair wire (six twists per foot) in all POPEX and POPIT installations for the data expansion loop wiring and the POPIT sensor loops. Run wires away from AC sources to prevent AC induction. If you suspect a noisy environment, use shielded cable. Refer to *Section 9.3 Installing the D8125 POPEX Module* on page 43.

9.3.6 POPIT Module Point Assignments

Six switches on each POPIT assign the module to a point number. For POPIT switch settings, refer to *Appendix B.1 Zonex 1 Points on page 81* or *Appendix B.2 Zonex 2 Points on page 82*.

9.3.7 Program Record Sheet

The *Appendix B.1 Zonex 1 Points on page 81* or *Appendix B.2 Zonex 2 Points on page 82* contains the **POPIT Switch Settings** for the D9127 POPITs. On the D9127T/U POPIT, switches are numbered 0 to 6, from left to right. Set the indicated switches to the ON position. If a dash (-) appears in the switch position, set the switch to the OFF position.

The second column contains the **Translation** of the point number into the Zonex format. Refer to *Point User Flag* in the *D9412GV4/D7412GV4/D7212GV4 Program Entry Guide (P/N: F01U218312)* for an explanation of this feature.

The third column contains the **Point Number** as shown at keypads.

The fourth column contains the **Point Index**. Refer to *Point Index Parameters* in the *D9412GV4/D7412GV4/D7212GV4 Program Entry Guide (P/N: F01U218312)* for an explanation of the point index.

The fifth column, **Area Assign**, shows the area to which the point is assigned.

The sixth column shows the **Debounce Count** for the point. Refer to *Debounce Count* in the *D9412GV4/D7412GV4/D7212GV4 Program Entry Guide (P/N: F01U218312)*.

The seventh column shows the BFSK/Relay report code, which associates a relay to an individual point.

The eighth column contains the **Custom Point Text** displayed at keypads for the point. The text is sent to the receiver when the control panel uses the Modem IIIa² format.

9.3.8 POPIT Labels

D9412GV4 off-board points are numbered 9 to 127 and 129 to 247. The D7412GV4 uses Points 9 to 75 only. D7212GV4 off-board points are numbered 9 to 40. The D9412GV4 reserves Points 128 and 248 for internal use. POPITs must be connected for Points 129 to 247 to expansion loops connected to POPEX #2.

Two sheets of peel-off POPIT labels are supplied with the D8125 POPEX Module. Use the sheet marked "Bank1" for Points 9 to 127. Use the sheet marked "Bank2" for Points 129 to 247.

Each label has two parts. Place the smaller part (with only the point number) on the chip. Place the larger part with the switch settings on the base of the POPIT. Set the switches and cover the POPIT.

Do **not** program two POPITs for the same point number. After programming all the points, perform a Service Walk Test. Refer to *Section 4.11 Service Walk Test* on page 47. If a point does not test, check the programming for a duplicated address.

Walk Test and Service Walk Test Do Not Show

Extra Points: If the point assignment switches on a POPIT or OctoPOPIT are set incorrectly, missing and extra points can occur. If the same point number is assigned to two or more POPITs or OctoPOPITs, none of the points with that number test correctly. Refer to *Section 9.1 Zonex Buses and D7212GV4 Terminals* on page 40.



For UL 864 Commercial Fire applications, refer to *Installing Combination Fire and Intrusion Alarm Systems* in the *D9412GV4/D7412GV4/D7212GV4 Approved Applications Compliance Guide* (P/N: F01U201525) for important information about combination fire and intrusion systems.

9.4 D8128D OctoPOPIT Module

Modules D8128, D8128A, or D8128B are incompatible with the D9412GV4, D7412GV4 or D7212GV4. Use only the D8128D OctoPOPIT Module. Using Modules D8128, D8128A, or D8128B can cause intermittent Missing and Restoral Reports.

9.4.1 Description

The D8128D OctoPOPIT Module combines the functions of the D8125 POPEX Module and the D9127 POPIT Modules to provide eight off-board points in a single module. You can wire both D8128D OctoPOPIT and D8125 POPEX Modules in parallel to the Zonex Bus terminals on the same control panel.

Review *Section 6.0 Power Outputs* on page 30 to ensure that there is enough power for the OctoPOPITs and other powered devices that will be connected to the system.

Up to thirty D8128D Modules can be connected to the D9412GV4 Control Panel. Up to nine D8128Ds can be connected to the D7412GV4 Control Panel (three points can be used on the last OctoPOPIT). Up to four D8128Ds can be connected to the D7212GV4 Control Panel (three points can be used on the last OctoPOPIT).

9.4.2 Listings

The D8128D OctoPOPIT Module is UL Listed for Local or Police Connected Burglary Alarm, Central Station Burglary Alarm, Household Burglary Alarm applications, and commercial fire applications (UL 864 and NFPA 72).

The D8128D is also suitable for fire supervisory applications, such as indicating circuit supervision (using the D192G Bell Circuit Supervision Module), sprinkler supervision, and valve tamper protection.

Requirements for Fire Initiation Applications

Non-powered, fire initiating devices such as pull-stations, heat detectors, and UL Listed four-wire smoke detectors can be connected directly to the point inputs on the D8128D.



For UL 864 Commercial Fire applications, refer to *Installing Combination Fire and Intrusion Alarm Systems* in the *D9412GV4/D7412GV4/D7212GV4 Approved Applications Compliance Guide* (P/N: F01U201525) for important information about combination fire and intrusion systems.

The D125B Dual Powered Loop Interface Module or the D129 Dual Class “A” Module zone outputs can be connected directly to the point inputs on the D8128D. Use the D125B to connect two-wire smoke detectors. Typically, the D129 is used for connecting waterflow switches.

The D125B or D129 and the OctoPOPIT can be mounted in the same enclosure with the control panel or in a separate enclosure connected to the control panel’s enclosure by a conduit not more than 6 m (20 ft.) in length.

Figure 16: D8128D OctoPOPIT Layout

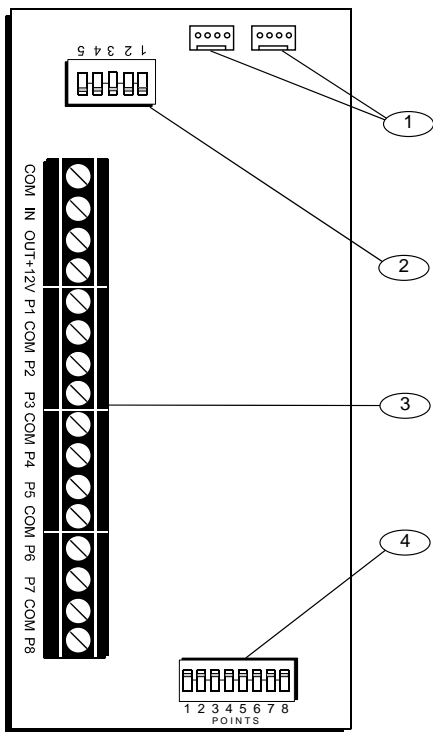

- 1 - Interconnect wiring connectors
- 2 - Address DIP switches
- 3 - Terminal strip
- 4 - Point DIP switches

9.4.3 Installation

For the most effective installation, use the following four-step process:

1. Set the OctoPOPIT switches. Refer to Section 9.4.4 Setting the OctoPOPIT Switches.
2. Physically mount the OctoPOPIT in the enclosure. Refer to Section 9.4.5 Mounting OctoPOPITs, page 48.
3. Wire the OctoPOPIT. Refer to Section 9.4.6 Wiring OctoPOPITs on page 48.
4. Wire the OctoPOPIT sensor loops. Refer to Section OctoPOPIT Sensor Loops on page 53.

9.4.4 Setting the OctoPOPIT Switches

The D8128D OctoPOPIT has two sets of DIP switches (Figure 16 on page 47). Use the DIP switches on the top of the unit (with the terminal strip along the left edge) to set the address for the OctoPOPIT. Use the DIP switches at the bottom of the unit to enable or disable individual points connected to the OctoPOPIT.

Address Switches

The switches on the D8128D OctoPOPIT set point assignments and line termination. These switches are easier to set before mounting the D8128D in the enclosure.

Switches 1, 2, 3, and 4 assign the OctoPOPIT sensor loops to point numbers on the control panel. Table 12 shows the OctoPOPIT switch settings for point assignments.

Switch 5 sets line termination. Refer to **Error! Reference source not found.**

Table 12: D8128D OctoPOPIT Switch Settings

ZONEX 1	D8128D Address Switches					ZONEX 2
Points 9 to 127	1	2	3	4	5	Points 129 to 247
9 to 16	ON	ON	ON	ON	*	129 to 136
17 to 24	ON	ON	ON	OFF	*	137 to 144
25 to 32	ON	ON	OFF	ON	*	145 to 152
33 to 40	ON	ON	OFF	OFF	*	153 to 160
41 to 48	ON	OFF	ON	ON	*	161 to 168
49 to 56	ON	OFF	ON	OFF	*	169 to 176
57 to 64	ON	OFF	OFF	ON	*	177 to 184
65 to 72	ON	OFF	OFF	OFF	*	185 to 192
73 to 80	OFF	ON	ON	ON	*	193 to 200
81 to 88	OFF	ON	ON	OFF	*	201 to 208
89 to 96	OFF	ON	OFF	ON	*	209 to 216
97 to 104	OFF	ON	OFF	OFF	*	217 to 224
105 to 112	OFF	OFF	ON	ON	*	225 to 232
113 to 120	OFF	OFF	ON	OFF	*	233 to 240
121 to 127	OFF	OFF	OFF	ON	*	241 to 247

* Line Termination Switch



For the D8128D OctoPOPITs assigned to Points 121 to 127, 241, and 247, set Point Input Switch 8 to the OPEN position. D9412GV4 uses Points 9 to 127 on Zonex 1 and Points 129 to 247 on Zonex 2. D7412GV4 uses Points 9 to 75 on Zonex 1 only. D7212GV4 uses Points 9 to 40 on Zonex 1 only.

Table 13: Switch 5 Settings for Line Termination

Is a D8125 POPEX Module connected?	Switch 5 Setting(s) on D8128D OctoPOPIT(s)
No	Set Switch 5 of only one D8128D to ON
Yes	Set Switch 5 of all D8128Ds to OFF

Point DIP Switches

Each point connected to the D8128D is enabled by closing the respective DIP switch, or disabled by opening the DIP switch. For example, to disable a device connected to the P3 Terminal (Point 3), move DIP switch number 3 to the OPEN position.

Use the point DIP switches to disable conflicting points, such as when a D9210C Access Control Module must be assigned to a point that falls within the range of the D8128D OctoPOPIT. In this example, a D9210C is assigned to Point 20. On the same system, a D8128D OctoPOPIT is assigned to Points 17 through 24. Moving the DIP switch for Point 4 to the OFF position would effectively disable Point 20, allowing normal operation of the D9210C and the OctoPOPIT. Through panel configuration the Point Source prompt further protects from possible point addressing conflicts. A point can be ZONEX, Octo-input, SDI2 Wireless, or Door Point.

Terminate each OctoPOPIT sensor loop with a 1 kΩ EOL resistor. Attach a resistor even if you do not enable the loop.

9.4.5 Mounting OctoPOPITs

The D8128D OctoPOPIT Module can be installed in the enclosure with the control panel using standard four-conductor 0.8 mm (22 AWG) wire, or in a separate enclosure (Model D8103, D8103A, or D8109) up to 61 m (200 ft.) from the control panel using shielded (recommended) standard four-conductor 0.8 mm (22 AWG) wire. If using the D125B or D129, refer to the *Specifications* section of the *D8128D Installation Guide* (P/N: F01U070537) for cabling requirements.

For UL Listed systems, mount the D8128D in a tamper-proof enclosure. To install OctoPOPITs in the control panel’s enclosure, complete the following procedure. Use the D137 Mounting Bracket to install OctoPOPITs in enclosures with no module-mounting locations available.

1. Align the OctoPOPIT module using any of the four mounting locations in the enclosure. Refer to *Figure 2* on page 16.
2. Use the screws provided with the module to secure it in the enclosure.

9.4.6 Wiring OctoPOPITs



Warning: Disconnect all power to the control panel before beginning any work with the internal components. Serious injury could result from electrical shock.

1. Power down the control panel:
 - a. Disconnect the positive (red) battery lead at the battery.
 - b. Unplug the transformer.



A D8128D OctoPOPIT can be installed up to 61 m (200 ft.) from the control panel.

2. Connect the D8128D to the control panel using either of the following methods:
 - Wire the D8128D to the terminal strip on the side of the POPEX Module, **or**
 - Connect the D8128D using the interconnect wiring connectors (P1 and P2). Refer to *Using Interconnect Wiring* on page 52.



Caution - AC induction: Avoid installing Zonex data wires and Zonex input (sensor loop) wires around any AC conduit, wiring, or electrical devices that emit fields of electromagnetic interference (EMI).

Using the Terminal Strip

Refer to *Table 14*, *Figure 17* on page 50, and *Figure 18* on page 51 when using the terminal strip to connect the D8128D OctoPOPIT to the control panel.

D8128D	D9412GV4	D7412GV4
Common	Terminal 23	Terminal 23
Out	Zonex 1 = Terminal 27 Zonex 2 = Terminal 25	Terminal 27
In	Zonex 1 = Terminal 28 Zonex 2 = Terminal 26	Terminal 28
+12 V	Terminal 24	Terminal 24

Figure 17: Connecting D8128D OctoPOPITs to the D9412GV4

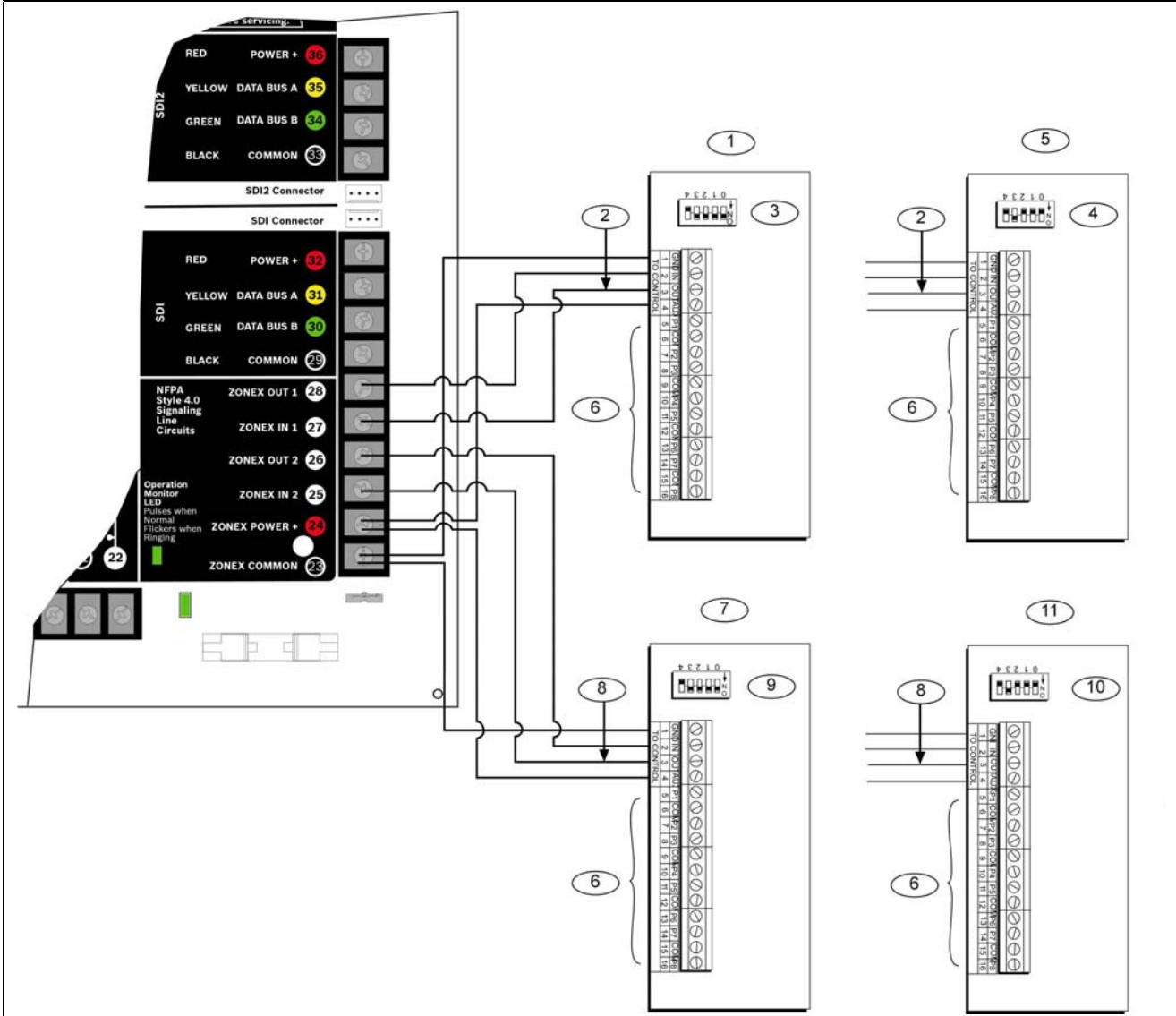

- | | |
|--|--|
| 1 - Zonex Bus 1, Switch 1 ON (Points 9 to 72) | 7 - Zonex Bus 2, Switch 1 ON (Points 129 to 192) |
| 2 - Bus 1 | 8 - Bus 2 |
| 3 - First address on Zonex Bus 1 | 9 - First address on Zonex Bus 2 |
| 4 - Last address on Zonex Bus 1 | 10 - Last address on Zonex Bus 2 |
| 5 - Zonex Bus 1, Switch 1 OFF (Points 73 to 127) | 11 - Zonex Bus 2, Switch 1 OFF (Points 193 to 240) |
| 6 - Sensor loops | |



Refer to *Address Switches* in *Section 9.4.4 Setting the OctoPOPIT Switches* on page 47 for information about making these switch settings. Refer to *Table 13* on page 48 for information about setting Switch 5.



For system supervision, do not use looped wire terminals. Break the wire run to provide supervision of the connections.

Figure 18: Connecting D8128D OctoPOPITs to the D7412GV4 or D7212GV4

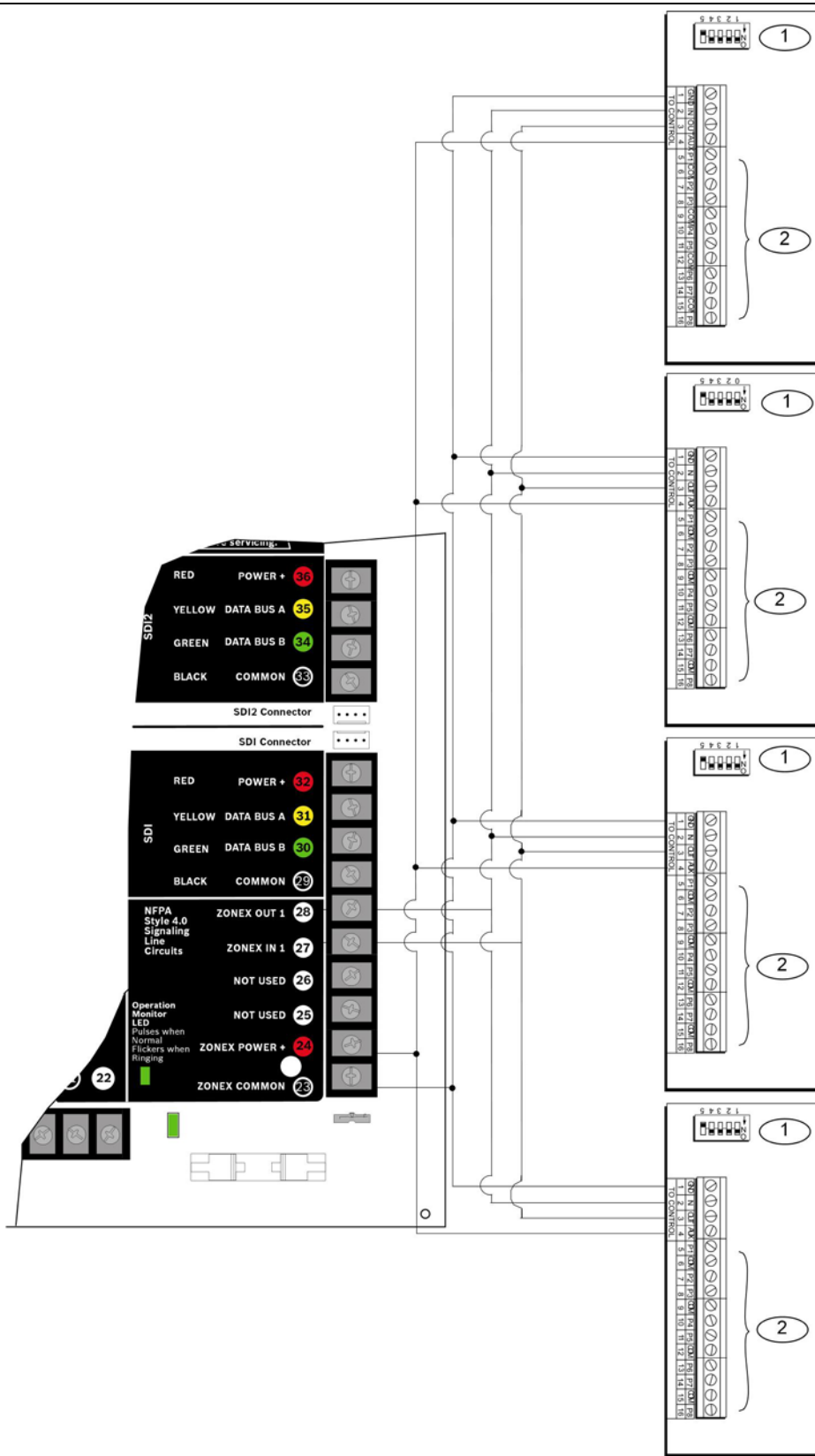

1 - Zonex 1 address

2 - Sensor loops



Refer to *Address Switches* in *Section 9.4.4 Setting the OctoPOPIT Switches* on page 47 for information about making these switch settings. Refer to *Table 13* on page 48 for information about setting Switch 5.



For system supervision, do not use looped wire terminals. Break the wire run to provide supervision of the connections.

Using Interconnect Wiring

Each D8128D Module is supplied with a 30 cm (12 in.) female-to-female interconnect wiring assembly.

P1 and P2 are interconnect wiring connectors that parallel the COM, IN, OUT, and +12.0 VDC terminals on the terminal strip. In installations with multiple D8128Ds, use these connectors (as opposed to terminals) with the supplied cable; however, when connecting D8128D Modules directly to the control panel, the terminal strip is easier to use.

The interconnect wiring connectors provided are "keyed" (interconnect wiring plug can fit in only one direction). Ensure that the connector is attached correctly: the red wire is on the bottom of P1 (or P2) and the black wire is on the top.

When connecting multiple D8128Ds to a control panel, you can connect the control panel terminals to P1 or the COM, IN, OUT, and +12V terminals on the first D8128D. Then connect P2 of the first D8128D to P1 of the second D8128D and so on (*Figure 19*).

Figure 19: Wiring Multiple D8128Ds Using Interconnect Wiring

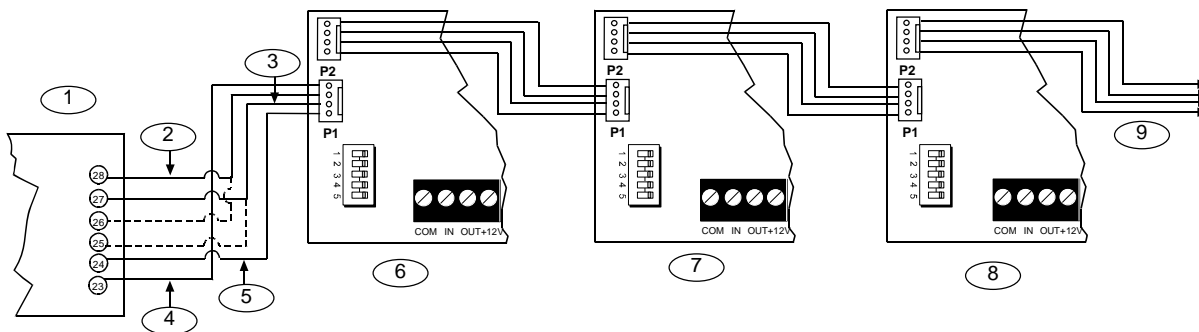

- 1 - D9412GV4 Control Panel
- 2 - Yellow
- 3 - Green
- 4 - Black
- 5 - Red

- 6 - First D8128D
- 7 - Second D8128D
- 8 - Third 8128D
- 9 - Up to 15 per Zonex Bus



A maximum of four D8128Ds can be installed on the D7212GV4.

9.4.7 OctoPOPIT Sensor Loops

Only the resistance on the loop limits the number of normally-open or normally-closed detection devices each sensor loop can supervise. Resistance on each sensor loop must be less than 100 Ω with the detection devices connected.

Certain UL and NFPA applications can limit the number of detection devices. Consult the appropriate UL or NFPA standards.

The OctoPOPIT detects open, short, closed, normal, and grounded circuit conditions on its sensor loops and sends the conditions to the control panel. Each sensor loop has an assigned point number and sends signals to the control panel separately.

Use twisted-pair wire for the OctoPOPIT sensor loops to avoid EMI problems. Run wires away from the premises telephone and AC wiring. If you suspect a noisy environment, use shielded cable.

The OctoPOPIT has two rows of terminal numbers. In the row nearest to the terminal blocks, the positive outputs for the sensor loops are labeled P1 to P8. Sensor loop outputs P1 and P2, P3 and P4, P5 and P6, and P7 and P8 share common terminals. The common terminals for each pair are labeled COM.

Terminate each OctoPOPIT sensor loop with a 1 k Ω

EOL resistor. Attach a resistor even if you do not enable the loop. The OctoPOPIT includes a D105BL resistor for each sensor loop. Refer to *Figure 20* on page 54.

Do not duplicate point assignments. Points do not function properly if assigned to an OctoPOPIT sensor loop and a POPIT, to two OctoPOPIT sensor loops, or to two POPITs.

Figure 20: D8128D OctoPOPIT Sensor Loops

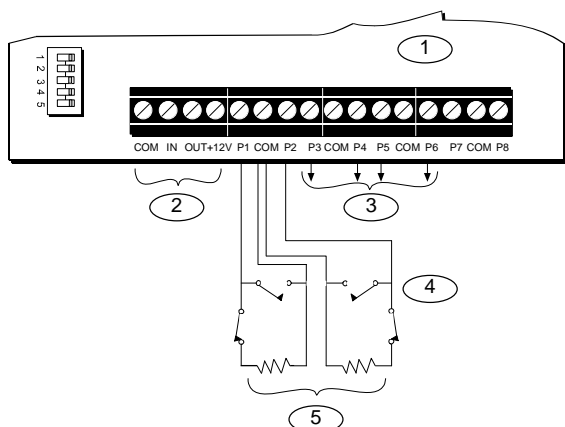

- 1 - D8128D OctoPOPIT
- 2 - To control panel
- 3 - To additional OctoPOPIT sensor loops
- 4 - OctoPOPIT sensor loops
- 5 - 1 kΩ EOL resistor (P/N: P105BL, package of eight)

9.5 Testing Off-Board Points

Use the Service Walk Test to test off-board points. Test to ensure that all off-board points operate properly.

Walk Test and Service Walk Test Do Not Show Extra Points: If the point assignment switches on a POPIT or OctoPOPIT are set incorrectly, missing and extra points can occur. If the same point number is assigned to two or more POPITs or OctoPOPITs, none of the points with that number test correctly. Refer to *Section 9.1 Zonex Buses and D7212GV4 Terminals* on page 40.

9.6 SDI2 Octo-input Point Modules

The D9412GV4 can use up to 24 B208 Octo-input point expansion modules to provide 191 of the 239 possible off-board points. The D7412GV4 can use up to 7 B208 Octo-input point expansion modules to provide 53 of the 67 possible off-board points. The D7212GV4 can use up to 3 B208 Octo-input point expansion modules to provide 24 of the 32 possible off-board points.

The B208 Octo-input point expansion modules provide a non-contiguous support of available off-board control panel points to allow concurrent use of Zonex or Wireless RF points.

Refer to Table 29: SDI2 Points on page 83 for point to module assignments.

9.7 Extra Point Events

Extra Point events are generated when the control panel detects a fault for a point that is enabled, but does not have a Point Index assigned. A point is considered enabled when its Point Source is set to Zonex, Octo-input (SDI2), or Door Point. A SDI2 Wireless point is considered enabled when its Point Source is Wireless and it has an RFID assigned.

On-board points cannot produce Extra Point events. Points in Service Bypass cannot produce Extra Point events.

Table 15 on page 55 shows when an Extra Point event is or is not generated. Table 16 on page 55 shows additional error conditions that can occur for the off-board points.

Table 15: Extra Point Events

An enabled point does not have an assigned Point Index and:	Extra Point event?	Additional Information
Data expansion bus is disconnected	No	Keypad does not annunciate or display a trouble condition.
Data expansion bus restores to normal condition after an open condition	Yes	<ul style="list-style-type: none"> Keypad annunciates and displays a trouble condition Extra Point is logged and might be programmed to send reports to the central station or to an on-site printer.
Point input changes status from normal to open or shorted	No	Keypad does not annunciate or display a trouble condition.
During a Service Walk Test, the point input changes status from normal to open or shorted	Yes*	<ul style="list-style-type: none"> Keypad annunciates and displays a trouble condition Extra Point is logged and might be programmed to send reports to the central station or to an on-site printer.

* The Service Walk Test never shows the electrical state of a point as “Extra.”

Table 16: Off-Board Point Errors

Error Condition	Result	Additional Information
+/- leg of the data expansion bus has a short circuit to earth ground, with Ground Fault Detect enabled	Ground Fault event	
+/- leg of the data expansion bus is disconnected	All POPITs beyond the disconnection send Missing report	
Data expansion bus has a short circuit	<ul style="list-style-type: none"> All POPITs send Missing report Pt Bus Trouble event 	When the data expansion bus restores, Pt Bus Restore event occurs. If any POPIT is connected to the data expansion bus without an assigned Point Index, an Extra Point event occurs.
+/- leg of the data expansion bus has a short circuit to the Common terminal on the control panel	<ul style="list-style-type: none"> All POPITs send Missing report Pt Bus Trouble event 	
Terminal 26, 28, or 94 has a short circuit to a Common terminal	No Pt Bus Trouble event occurs	
Terminal 25, 27, or 94 has a short circuit to a Common terminal	<ul style="list-style-type: none"> Pt Bus Trouble event Keypad displays: SERVC ZONEX 1 	
Terminals 27 and 28 have a short circuit together	<ul style="list-style-type: none"> Pt Bus Trouble event Keypad displays: SERVC ZONEX 1 	

10.0 Off-Board Relays

10.1 D8129 OctoRelay

Use the D8129 OctoRelay to add relay outputs to the system in groups of eight. On the D9412GV4, up to 128 OctoRelay outputs (relay numbers 1 to 128) can be added to the system using 16 OctoRelays. D7412GV4 allows up to 64 relay outputs. The D7212GV4 allows up to 24 off-board relay outputs. Review *Section 6.0 Power Outputs* on page 30 to ensure that enough power is provided for the OctoRelays and other powered devices that are connected to the system.

OctoRelays for relay numbers 1 to 64 connect to Zonex 1, Terminal 28. OctoRelays for relay numbers 65 to 128 connect to Zonex 2 (D9412GV4 only), Terminal 26. Refer to *Figure 21* or *Figure 22* on page 57.

Alarm output, auxiliary relay, sensor reset, arming status, point status, alarm memory, or remote functions can be assigned to the OctoRelay outputs individually. Refer to *Relay Parameters* in the *D9412GV4/D7412GV4/D7212GV4 Program Entry Guide (P/N: F01U218312)* for programming details.

D8129 Restricted for Fire Systems: D8129 relay outputs are not supervised and cannot be used in fire or combined fire and burglary installations for primary indicating devices.

Figure 21: D8129 Connections to the D9412GV4

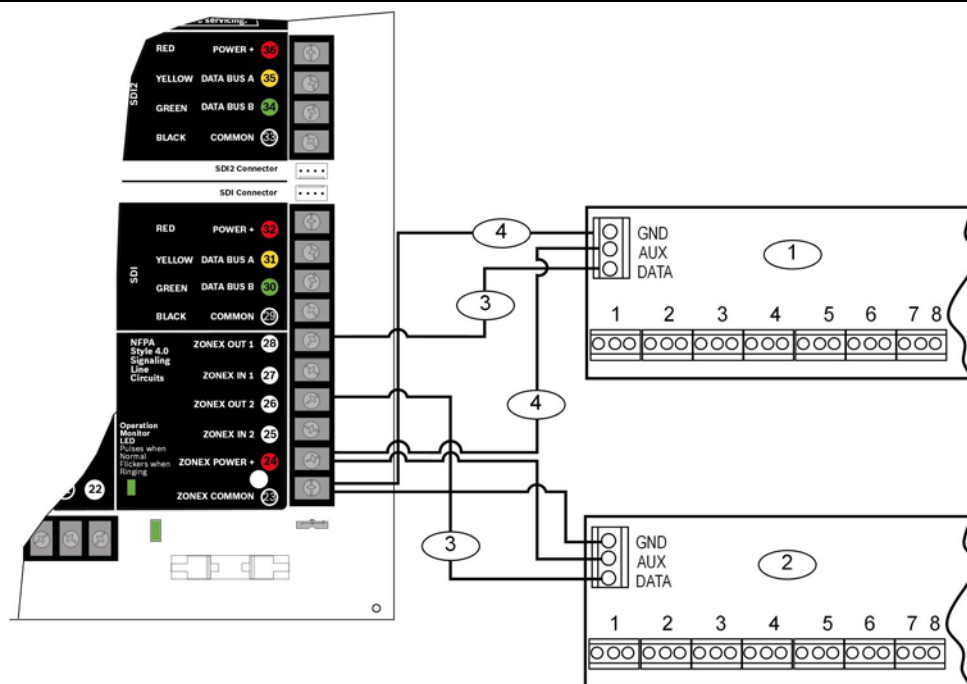

- 1 - D8129 OctoRelays for relay numbers 1 to 64. Connect OctoRelays in parallel.
- 2 - D8129 OctoRelays for relay numbers 65 to 128. Connect OctoRelays in parallel.
- 3 - Power limited
- 4 - Power limited

Figure 22: D8129 Connections to the D7412GV4 or D7212GV4

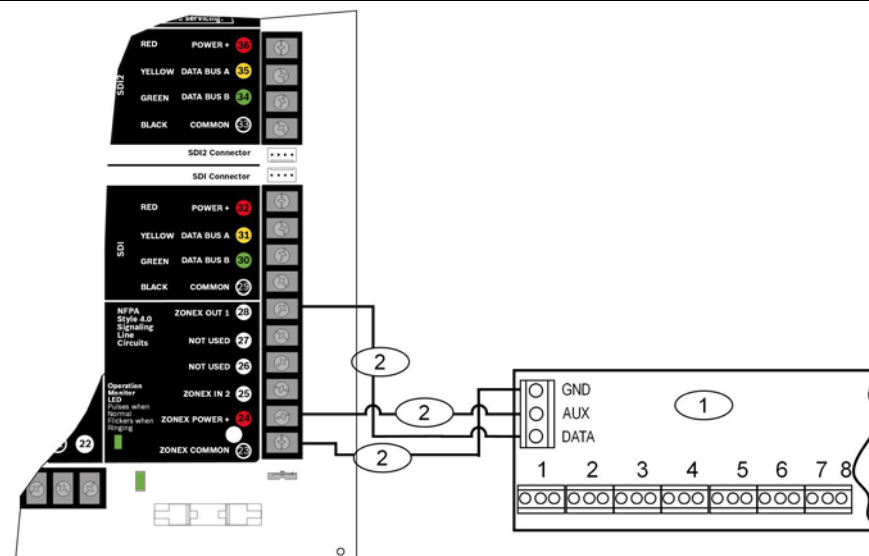

- 1 - D8129 OctoRelays for relay numbers 1 to 64. Connect OctoRelays in parallel.
- 2 - Power limited

10.1.1 Configuring the D8129 OctoRelay

Five switches on the OctoRelay determine the relay numbers for the eight relay outputs (Table 17).

Table 17: D8129 OctoRelay Switch Settings		
Panel Relay Number	D8129 OctoRelay Switch Setting	On Panel, Connect D8129 to:
1 to 8	Off-On-On-On-On	Zonex 1 Terminal 28
9 to 16	On-Off-On-On-On	Zonex 1 Terminal 28
17 to 24	Off-Off-On-On-On	Zonex 1 Terminal 28
D7212G Maximum		
25 to 32	On-On-Off-On-On	Zonex 1 Terminal 28
33 to 40	Off-On-Off-On-On	Zonex 1 Terminal 28
41 to 48	On-Off-Off-On-On	Zonex 1 Terminal 28
49 to 56	Off-Off-Off-On-On	Zonex 1 Terminal 28
57 to 64	On-On-On-Off-On	Zonex 1 Terminal 28
D7412G Maximum		
65 to 72	Off-On-On-On-On	Zonex 2 Terminal 26
73 to 80	On-Off-On-On-On	Zonex 2 Terminal 26
81 to 88	Off-Off-On-On-On	Zonex 2 Terminal 26
89 to 96	On-On-Off-On-On	Zonex 2 Terminal 26
97 to 104	Off-On-Off-On-On	Zonex 2 Terminal 26
105 to 112	On-Off-Off-On-On	Zonex 2 Terminal 26
113 to 120	Off-Off-Off-On-On	Zonex 2 Terminal 26
121 to 128	On-On-On-Off-On	Zonex 2 Terminal 26

10.1.2 Relay Outputs



Relay outputs can activate when you are setting the OctoRelay switches or programming the control panel.

Disconnect equipment connected to relay outputs when you perform these functions.

Each OctoRelay output provides a Form C dry contact rated for 1.0 A at 12.0 VDC. Normally-open, common, and normally-closed terminals are available for each relay output. When an individual output is activated, continuity exists between the normally-open and common terminals. When the output is not activated, continuity exists between the normally-closed and common terminals.

10.1.3 Installation

Set the switches on the OctoRelay before installing it in the enclosure. Refer to Section 10.1.1 *Configuring the D8129 OctoRelay*.

Install the OctoRelay in the enclosure with the control panel (Figure 2 on page 9) or in an adjacent enclosure that is no more than 1.5 m (5 ft.) from the control panel. Use 1.5 mm (16 AWG) to 0.8 mm (22 AWG) wire.

To install OctoRelays in the enclosure with the control panel:

1. Align the module with one of the mounting locations in the enclosure (refer to Figure 2 on page 9).
2. Using the screws provided with the module, secure the module in the enclosure.

Use the D137 Mounting Bracket or D9002 Mounting Skirt to install OctoRelays in enclosures with no available module mounting locations.

10.1.4 Wiring Connections

Power down the control panel to connect OctoRelays. Refer to Figure 21 or Figure 22 on page 57.



OctoRelays for Relays 1 to 24 connect to Zonex 1, Terminal 28 on the D7212GV4 only.

OctoRelays for Relays 1 to 64 connect to Zonex 1, Terminal 28 on the D7412GV4 only.

OctoRelays for Relays 65 to 128 connect to Zonex 2, Terminal 26 on the D9412GV4 only.

Only one OctoRelay is shown wired to each Zonex bus in Figure 21 on page 57. Wire additional OctoRelays in parallel. Review Section 6.0 *Power Outputs* on page 30 for information about providing enough power for the relays.

The number of D8129 OctoRelays that can be connected to each Zonex terminal on the D9412GV4 control panels is limited by the number of D8128D OctoPOPITs connected.



Using D8129 OctoRelays and D8128D OctoPOPITs together on the same Zonex terminals is limited and depends on the number of D8128 OctoPOPITs and D8129 OctoRelays connected to a single Zonex Bus.

Refer to *Table 18* for information about the maximum number of D8128Ds and D8129s you can connect to a single Zonex bus.

Table 18: Number of D8128Ds Used with D8129s

If the number of D8128Ds connected to a single Zonex bus is:	Do not connect more than this number of D8129s:
9	6
10	5
11	4
12	3
13	1
14	1

10.2 D811 Arm Status Relay Module

The D811 Arm Status Relay Module allows the addition of a single off-board relay output to the system. Alarm output, auxiliary relay, sensor reset, arming status, point status, alarm memory, or remote functions can be assigned to the D811 relay output. It is not restricted to the Arming Status Mode only.

Relay Numbers for D811 Not Programmable: If the D811 is connected to Zonex 1, Terminal 28, use relay number 53 for the relay output. If the D811 is connected to Zonex 2, Terminal 26 on the D9412GV4, use relay number 117 for the relay output.

D811 Modules connect as shown in *Figure 23* and *Figure 24* on page 61. Review *Section 6.0 Power Outputs* on page 30 to ensure that enough power is provided for the powered devices that connect to the system. Refer to *Relay Parameters* in the *D9412GV4/D7412GV4/D7212GV4 Program Entry Guide (P/N: F01U218312)* for programming details.

D811 Restricted for Fire Systems: The D811 relay output is not supervised and cannot be used in fire or combined fire and burglary installations for primary indication devices.

10.2.1 Relay Output



Relay outputs can activate when you are programming the control panel.

Disconnect equipment connected to relay outputs when you perform this function.

Each D811 relay output provides a Form C dry contact rated for 1.0 A at 12.0 VDC. Normally-open, common, and normally-closed terminals are available. When an individual output is activated, continuity exists between the normally-open and common terminals. When the output is not activated, continuity exists between the normally-closed and common terminals.

10.2.2 Installation

Install the D811 in the enclosure with the control panel or in an adjacent enclosure no more than 1.5 m (5 ft.) from the control panel. Use 1.5 mm (16 AWG) to 0.8 mm (22 AWG) wire.

To install D811 Modules in the enclosure with the control panel:

1. Align the D811 Module with any of the four mounting locations in the enclosure (*Figure 2* on page 16).
2. Using the screws provided with the module, secure it in the enclosure.

Use the D137 Mounting Bracket or D9002 Mounting Skirt to install D811 Modules in enclosures with no available module mounting locations.

10.2.3 Wiring Connections

Power down the control panel to connect D811 Modules as shown in *Figure 23* and *Figure 24* on page 61.



The D811 for Relay 53 connects to Zonex 1.

The D811 for Relay 117 connects to Zonex 2 on the D9412GV4.

10.3 SDI2 Octo-output Relay Modules

The D9412GV4 can use up to 12 B308 Octo-output relay modules to provide 72 of the 128 supported off-board relays.

The D7412GV4 can use up to 6 B308 Octo-output relay modules to provide 48 of the 64 supported off-board relays.

The D7212GV4 can use up to 3 B308 Octo-output relay modules to provide all 24 of the supported off-board relays.

The B308 Octo-output relay modules provide a non-contiguous support of available off-board control panel relays to allow concurrent use of Zonex relays. For example, off-board relay numbers 9 and 10, 20 and 21 can only be on a Zonex OctoRelay module. Refer to *Table 25* on page 71 for relay number to module assignments.

Figure 23: D811 Arm Status Relay Module Wiring to the D9412GV4

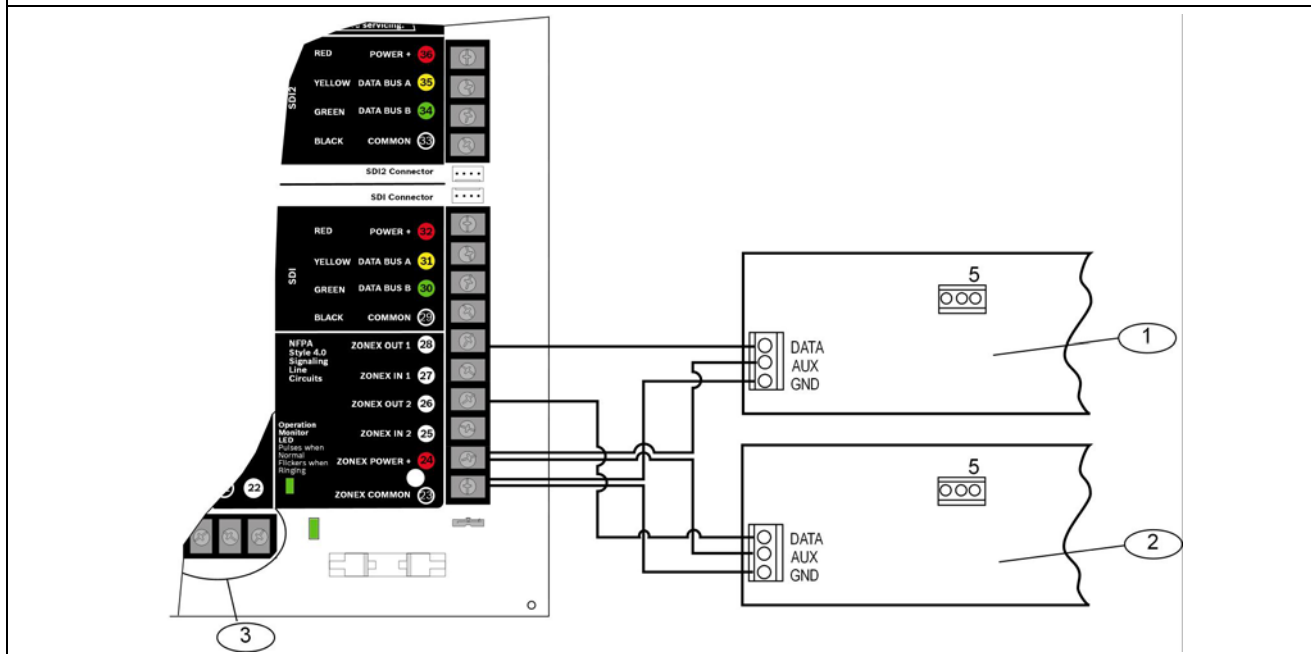

- 1 - D811 for Relay 53
- 2 - D811 for Relay 117

3- On-board points

Figure 24: D811 Arm Status Relay Module Wiring to the D7412GV4 or D7212GV4

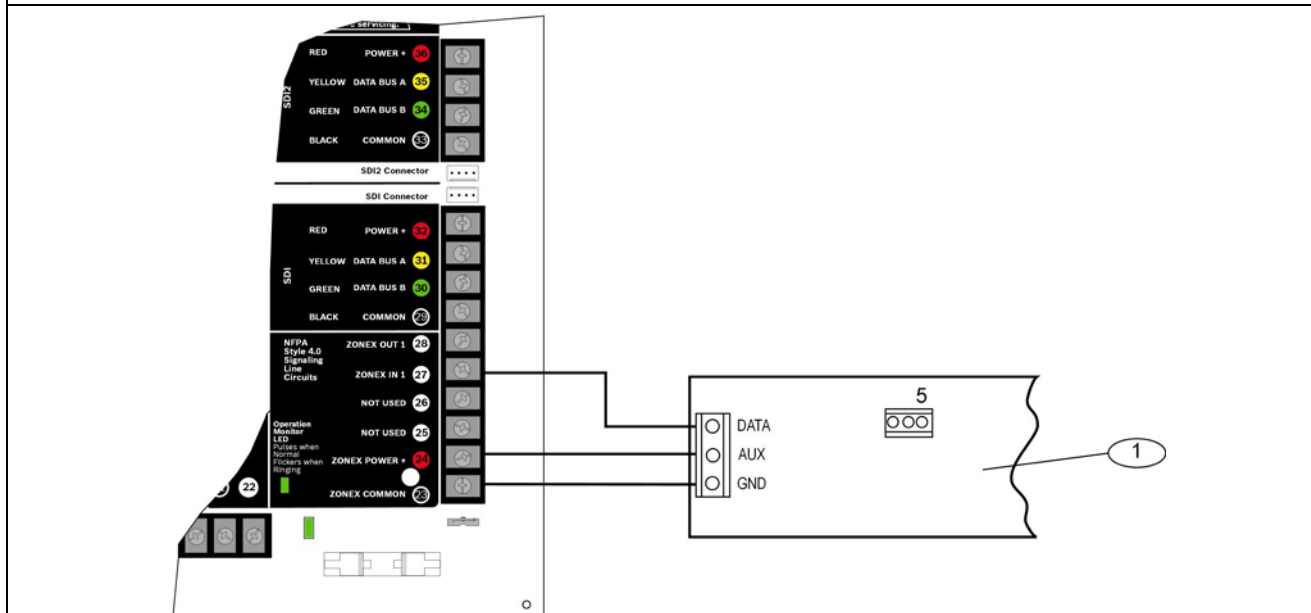

- 1 - D811 for Relay 53

11.0 Arming Devices

11.1 Description

Keypads, maintained or momentary contact keyswitches, or a combination of the two are used to arm and disarm areas. The D9412GV4 can support up to 32 areas. The D7412GV4 can support up to 8 areas. The D7212GV4 can support up to 4 areas. Refer to 3.3.5 *Areas and Accounts* on page 12 for a description of areas.



For UL 864 Commercial Fire applications, refer to *Installing Combination Fire and Intrusion Alarm Systems* in the *D9412GV4/D7412GV4/D7212GV4 Approved Applications Compliance Guide* (P/N: F01U201525) for important information about combination fire and intrusion systems.

11.2 Keypad Terminals 29 to 32

The Bosch Security Systems, Inc. keypad is a four-wire powered device used to arm and disarm areas, announce complete system status, initiate system tests, and control many functions of the security system.

The D9412GV4 or D7412GV4 systems can supervise up to 16 keypads (D7212GV4 can supervise up to 8 keypads). The control panel sends a Serial Device Trouble Report, SDI FAILURE, in the Modem IIIa² format or Expansion Module Failure (333) in Contact ID format, if it loses communication with a supervised keypad. CALL FOR SERVICE appears in any keypad that loses communication with the control panel, if the keypad has text display capability. SERVC KEYPAD appears at all other keypads connected to the system.

A total of 32 unsupervised keypads can be connected to the system. The number of supervised keypads, number of areas, and the available power affect the total number of keypads that can be connected to the system. Refer to *Keypad* in the *D9412GV4/D7412GV4/D7212GV4 Program Entry Guide* (P/N: F01U170807) for complete programming details on keypad options.

Five types of keypads are available for use with the system.

- **D1255/D1255B/D1255RB:** 16-character alphanumeric display for general use. Addressable to all 16 SDI addresses.
- **D1256/D1256RB:** Text display keypad with keys designated for local fire alarm control. Addressable to all 16 SDI addresses.
- **D1257/D1257RB:** Text display keypad for fire annunciation. Addressable to all 16 SDI addresses.
- **D1260/D1260B:** Easy-to-read, 4-line by 20-character LCD display with eight “soft” keys to display simple selections. Addressable SDI Addresses 1-8.
- **D720/D720B:** LED display keypad appropriate for use as a single area keypad with up to eight points. Addressable to all 16 SDI addresses.



D1255 and D720 are available in white (D1255W and D720W) or red (D1255R and D720R).



To meet UL 864 requirements for Commercial Fire applications, use a D1255RB, D1256RB, or D1257RB for a fire keypad or fire annunciator.

For operational information, refer to the user’s guide for the specific keypad.

11.2.1 Assigning an Address for the Keypad

Switches on the keypad assign an address (1 to 16). The address determines if the keypad is supervised, the scope of the keypad, and to what area the keypad is assigned. Refer to *Keypad Assignment* in the *D9412GV4/D7412GV4/D7212GV4 Program Entry Guide* (P/N: F01U218312) for a complete description of addresses.

Table 19 shows the correct switch setting for each address.

Table 19: Keypad Address Settings

Address	Switch					
	1	2	3	4	5	6
Address #1	ON	ON	ON	ON	Tone ON/OFF Encoding	ON
Address #2	OFF	ON	ON	ON		ON
Address #3	ON	OFF	ON	ON		ON
Address #4	OFF	OFF	ON	ON		ON
Address #5	ON	ON	OFF	ON		ON
Address #6	OFF	ON	OFF	ON		ON
Address #7	ON	OFF	OFF	ON		ON
Address #8	OFF	OFF	OFF	ON		ON
Address #9	ON	ON	ON	OFF		ON
Address #10	OFF	ON	ON	OFF		ON
Address #11	ON	OFF	ON	OFF		ON
Address #12	OFF	OFF	ON	OFF		ON
Address #13	ON	ON	OFF	OFF		ON
Address #14	OFF	ON	OFF	OFF		ON
Address #15	ON	OFF	OFF	OFF		ON
Address #16	OFF	OFF	OFF	OFF		ON

Wire Limits for Individual Devices

Refer to the installation instructions for each device for wire length specifications.

Extra Power for More Keypads

The D1255 and D1255B Keypads draw 104 mA when idle. They draw 206 mA with the keys lit and the sounder activated. Review *Section 6.0 Power Outputs* on page 30 to determine the total power output requirements for the system.

One or more D8132 Battery Charger/Power Supply Modules can be added for the number of keypads used. *Figure 25* on page 64 shows the D8132 powering keypads in a stand-alone configuration.

For UL Certificated accounts, use a UL Listed auxiliary 12.0 VDC or 24 VDC regulated, power-limited power supply for Fire Protective Signaling Units and Commercial or Residential Burglar Units. The D8132 is not UL Listed as a stand-alone power supply.

11.2.2 Installation

Refer to the keypad installation manuals for installation and mounting instructions. Keypads connect to the control panel in parallel (*Table 20*).

Table 20: Keypad Connections

Terminal	Function	Keypad Wire Color	Function
32*	POWER +	Red	+12.0 VDC
31	DATA BUS A	Yellow	Data
30	DATA BUS B	Green	Data
29	COMMON	Black	Common

* Connect with at least 1.5 m (5 ft.) of 0.8 mm (22 AWG) wire (4.3 m [14 ft.] of 1.2 mm [18 AWG] wire).

Switching the Green and Yellow Wires Affects Other Keypads:

Connecting the green wire incorrectly from the keypad to Terminal 31 and the yellow wire to Terminal 30 causes other keypads connected to the control panel to go blank or to sound random beep tones.

You can connect devices to the data bus (Terminals 30 and 31) by parallel wire run from the control panel to each device, wire from device to device, or a combination of the two using a maximum of 4572 m (15000 ft) of 0.8 mm (22 AWG) wire for all devices connected to the SDI Bus combined.



The control panel and the D8132 (or other power supply) must share COMMON.

Figure 25 on page 64 shows the common form of the D8132 Module connected to the common on the keypad and the common on the control panel. Any stand-alone power supply, powering any device connected to the control panel, must also be connected to a common terminal on the control panel.

If using the ground fault detection capability on the control panels with an external power supply, ensure that the external selected power supply isolates its earth ground connection from the negative side of the auxiliary power output. External power supplies that do not isolate earth ground can cause ground fault conditions on the control panel.

Figure 25: External Power to SDI Devices

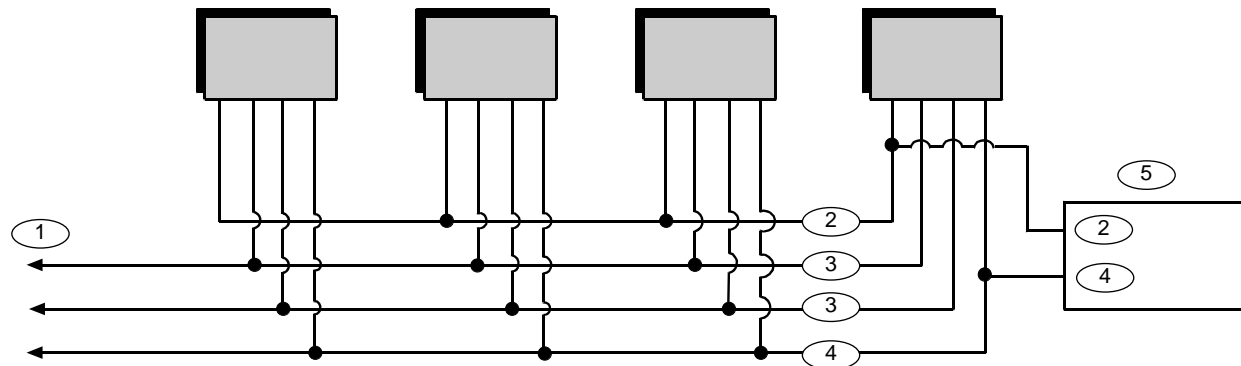

1 - To control panel

2 - +12.0 VDC

3 - Data

4 - Common

5 - D8132 or external power supply

11.3 D279A Independent Zone Control

Any point can be programmed so that the D279A Independent Zone Control operates as independent point control (arming and disarming the point).

Refer to *Point Assignments* in the *D9412GV4/D7412GV4/D7212GV4 Program Entry Guide* (P/N: F01U218312) for programming information. Refer to the *D279A Operation and Installation Instructions* (P/N: 46458) for wiring and operation instructions.

11.4 Keyswitch

11.4.1 Description

A maintained or momentary contact arming station (keyswitch) can be connected to master arm or disarm any of the areas in the system. The keyswitch is connected to an on-board or off-board point's sensor loop. Relays can be programmed to activate arming status LEDs for keyswitch arming stations. Refer to *Relays* in the *D9412GV4/D7412GV4/D7212GV4 Program Entry Guide* (P/N: F01U218312).

11.4.2 Programming

Refer to *Point Assignments* in the *D9412GV4/D7412GV4/D7212GV4 Program Entry Guide* (P/N: F01U218312) for the correct programming for points used for keyswitches.

11.4.3 Installation

For maintained switches, connect the EOL resistor for the point at the keyswitch so that the switch opens the circuit when it operates. A short on the circuit produces an alarm if the area is armed and a trouble if it is disarmed. Refer to *Figure 26* on page 65.

For momentary keyswitches, connect the EOL resistor at the keyswitch point so that when the keyswitch operates, it shorts the resistor. An open on the circuit causes an alarm if the area is armed and a trouble if it is disarmed. Refer to *Figure 26* on page 65.

11.4.4 Operation

Maintained Contact

If the point to which the keyswitch is connected is programmed for a maintained contact, an open on the arming circuit arms the area. All faulted points are force armed, regardless of the entry in the FA Bypass Max program item. Returning the circuit to normal disarms the area. Refer to *Area Parameters* and *Point Assignments* in the *D9412GV4/D7412GV4/D7212GV4 Program Entry Guide* (P/N: F01U218312).

Momentary Contact

If the point to which the keyswitch is connected is programmed for a momentary contact, shorting the arming circuit toggles the area's arming state between armed and disarmed. All faulted points are force armed, regardless of the entry in the FA Bypass Max program item. Refer to *Point Assignments* in the *D9412GV4/D7412GV4/D7212GV4 Program Entry Guide* (P/N: F01U218312).

Silencing the Bell

To silence the bell (stop Alarm Bell output) if the system is armed, position the keyswitch to disarm the area. If the area is disarmed, turn the keyswitch once to start the arming process. Turning the keyswitch a second time stops the arming process and silences the bell.

Figure 26: Keyswitch Wiring

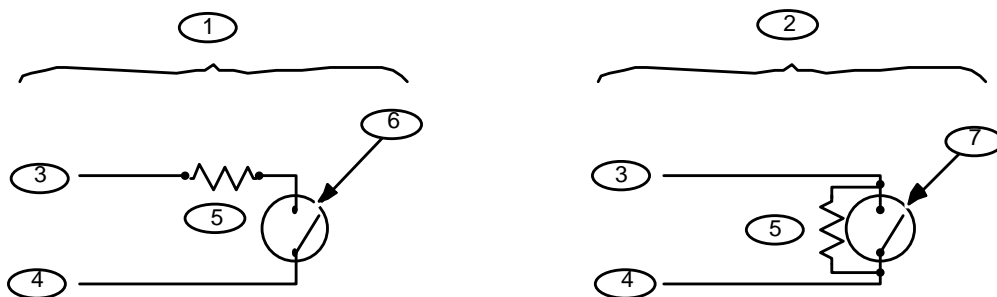

1 - Maintained keyswitch

2 - Momentary keyswitch

3 - Common

4 - Point input

5 - 1 kΩ or 33 kΩ resistor *

6- Open on a circuit arms the area

7 - Short on a circuit toggles the arming state

* Use 1 kΩ EOL resistors if using one of the zones on the control panel or an OctoPOPIT. Use a 33 kΩ resistor if using a POPIT.

12.0 SDI Devices

12.1 Description

The GV4 Series Control Panels can support a number of accessory devices from the SDI Bus using Terminals 29 through 32. Some devices include the D1255 and D1255B Keypads (refer to *Section 11.0 Arming Devices* on page 62), D9131A Parallel Printer Interface Module, D9210C Access Control Interface Module, DX4010i RS-232 Serial Interface Module, ITS-DX4020-G GPRS/GSM Communicator, and DX4020 Network Interface Module.



For UL 864 Commercial Fire applications, refer to *Installing Combination Fire and Intrusion Alarm Systems* in the *D9412GV4/D7412GV4/D7212GV4 Approved Applications Compliance Guide* (P/N: F01U201525) for important information about combination fire and intrusion systems.

12.2 Installation

For complete installation instructions, consult the operation and installation guide for the specific SDI device. SDI devices connect to the control panel in parallel (*Table 21*).

These devices can share power with the control panel or be powered by a stand-alone power source.

SDI Devices			
Terminal	Function	Wire Color	Function
32	POWER +	Red	+12.0 VDC
31	DATA BUS 1	Yellow	Data
30	DATA BUS B	Green	Data
29	COMMON	Black	Common



A stand-alone power supply powering the SDI device must also be connected to a common terminal on the control panel.

Do not connect the earth ground for the stand-alone power supply to Terminal 10 on the control panel.

12.2.1 Open Wire Trouble on SDI

The GV4 Series Control Panels can detect an open wire fault in the data communication lines of the SDI bus. Any open wire on Terminals 30 or 31 result in a system fault trouble display on all keypads, and a general SDI Fault event sent to the central station.

12.3 D9131A Parallel Printer Interface Module

The Bosch Security Systems, Inc. D9131A Parallel Printer Interface Module is a four-wire powered device used to connect a standard parallel printer to a control panel. D9412GV4 can supervise three printers and the D7412GV4 or D7212GV4 can supervise one printer. A separate D9131A Parallel Printer Interface Module is necessary for each printer. The D9131A connects to the printer using a standard parallel printer cable.

12.3.1 Switch Settings

Switches on the D9131A assign a unique address (17 to 19) for each printer. The address determines if the printer is supervised, the area scope of the printers, and the area to which the printer is assigned. Refer to *Printer Parameters* in the *D9412GV4/D7412GV4/D7212GV4 Program Entry Guide* (P/N: F01U218312) for a complete description of addresses.

Table 22 shows the correct switch setting for each address.

Printer	Switch					
	1	2	3	4 ²	5	6
17	ON	ON	ON	ON	ON	ON
18 ¹	OFF	ON	ON	ON	ON	ON
19 ¹	ON	OFF	ON	ON	ON	ON

¹ D9412GV4 only.
² Switch ON = Header and form feed
4: OFF = No header and form feed

12.3.2 Supervision

Supervision includes:

- Proper operation of the SDI bus
- Proper connection of the printer cable between the printer and the D9131A
- Printer paper supply
- Printer selected (on-line)
- Printer power.

The control panel sends an SDI Failure Report to the receiver if communication with the printer interface fails. If an SDI failure occurs, SERVC PRINTER appears at the keypad. The report to the receiver includes the address of the troubled D9131A to indicate which printer needs service.

If an SDI device is supervised and Terminal 31 (SDI A+) becomes disconnected, the device can continue to operate normally, depending upon environmental conditions.

12.4 D9210C Access Control Interface Module (D9412GV4 and D7412GV4)

The Bosch Security Systems, Inc. D9210C Access Control Interface Module is a four-wire powered device providing connections for an access door point and door strike. The D9412GV4 can supervise eight Wiegand Control Modules, the D7412GV4 can supervise two. Each D9210C supports one door to control access. Programming allows each access door to be configured independently.

12.4.1 Access

Using Wiegand style cards or tokens, the D9210C can allow access for up to 999 cards or tokens on the D9412GV4, and up to 399 on the D7412GV4. User access authority can be configured to restrict access to certain doors or to certain periods of time. The reading of access cards, in addition to granting access, can control whether the system disarms.

12.4.2 Switch Settings

Rotary switches on the D9210C assign a unique address to each module. *Table 23* shows the correct switch setting for each D9210C address.

Table 23: Address Switch Settings for Access Control Module

Door Controller	Combined Rotary Switch Settings	Fail Safe Response
Default	0	-
1	81	Unlock
2*	82	Unlock
3	83	Unlock
4	84	Unlock
5	85	Unlock
6	86	Unlock
7	87	Unlock
8	88	Unlock
1	91	Lock
2*	92	Lock
3	93	Lock
4	94	Lock
5	95	Lock
6	96	Lock
7	97	Lock
8	98	Lock

*D7412GV4 supports doors 1 & 2

12.5 SDI Addresses 88 and 92

SDI Addresses 88 and 92 are available with the GV4 Series Control Panels and are used for several different applications. Only one device can be assigned to SDI Address 88 at a time. Likewise, only one device can be assigned to SDI Address 92 at a time. When the Reset Pin (labeled S1) is closed, all SDI communication module addresses are automatically enabled for RPS communication without restriction. Refer to Figure 4: Reset Pin on page 18 to locate the reset pin.

12.5.1 Local RPS Programming

Use the DX4010i or the DX4010V2 serial communication module at SDI Address 88 or SDI Address 92 to locally connect with RPS in Enhanced Direct mode. This connection method also allows diagnostic and history retrieval.



When a serial communication modules is installed at an SDI Address, it cannot be used for central station communications. UL requires that serial communication modules be used for programming only.

12.6 SDI Network Interface Modules

The GV4 Series Control Panels support up to four network interface modules that provide connection for two-way communication over Ethernet networks. Up to two Bosch Security Systems, Inc. DX4020 Network Interface Modules can be installed on the SDI bus. Likewise, up to two Bosch Security Systems, Inc. B420 Ethernet Communication Modules can be installed on the SDI2 bus. Refer to *Section 13.5 B420 Ethernet Communication Module* section for details regarding the SDI2 network interface modules.

For programming information on enhanced communications, refer to the *D9412GV4/D7412GV4/D7212GV4 Program Entry Guide (P/N: F01U218312)*.

The DX4020 can be installed on the SDI bus up to 305 m (1000 ft) from the control panel or auxiliary power supply using 0.8 mm (22 AWG) wire.

The ITS-DX4020-G GPRS/GSM IP Communicator enables two-way IP or dialed communication over a commercial GPRS/GSM network. Typical applications are event reporting to a central monitoring station and remote access to Bosch intrusion control panels.

The ITS-DX4020-G GPRS/GSM IP Communicator has two modes; GPRS uses Modem IIIa²; and GSM uses Contact ID.

The B420 modules can be installed on the SDI bus when configured to emulate DX4020 modules. Regardless of bus type, the modules can be up to 305m (1000ft) from the control panel or auxiliary power supply using 0.8 mm (22 AWG) wire.

For programming information refer to the *ITS-DX4020-G GPRS/GSM IP Communicator Installation and Operation Guide (P/N: F01U163066)*.

12.6.1 Address Settings

The DX4020 has specific DIP switch settings for SDI Addresses 88 and 92 when using the DX4020 for Remote Programming Software (RPS) or enhanced communications in a local-area network (LAN) or wide-area network (WAN) environment. Refer to *Figure 27* for the correct switch settings.

12.6.2 Supervision

Supervision of Network Interface Modules at SDI Addresses 88 and 92 are enabled automatically when used to communicate with a central station network receiver. Supervision ensures reliable operation between the module and the control panel.

If supervised and the module does not respond to control panel supervision polls, then a system fault message appears at the keypad. The report to the receiver includes the address of the troubled module indicating which module needs service.

Figure 27: DX4020 DIP Switch Settings

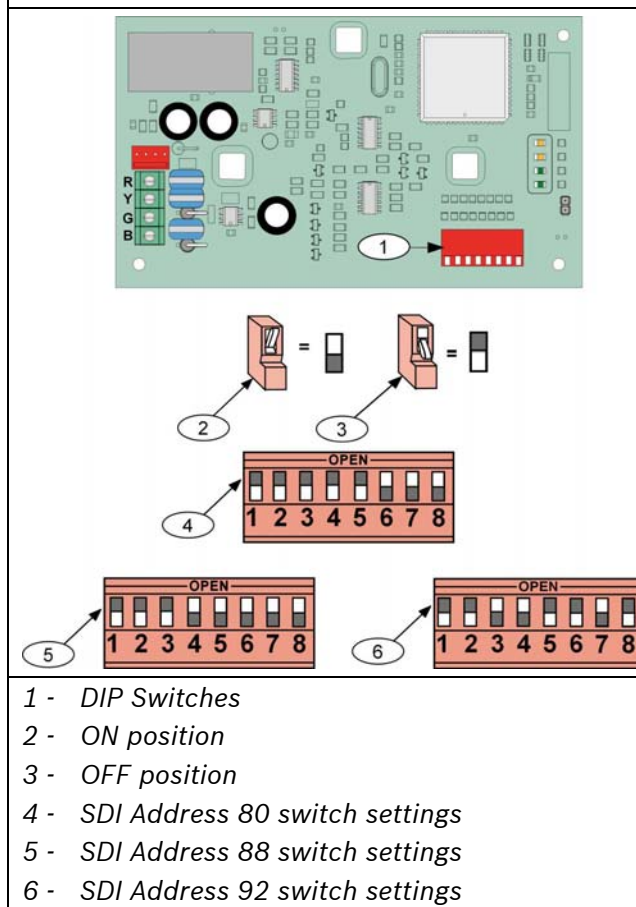

13.0 SDI2 Devices

13.1 Description

GV4 Series Control Panels can support a number of accessory devices from the SDI2 Bus using Terminals 33 through 36. Some devices include the B208 Octo-input Module, the B308 Octo-output Module, and the B820 SDI2 Inovonics Interface Module.



For UL 864 Commercial Fire applications, refer to *Installing Combination Fire and Intrusion Alarm Systems* in the *D9412GV4/D7412GV4/D7212GV4 Approved Applications Compliance Guide* (P/N: F01U201525) for important information about combination fire and intrusion systems.

13.2 Installation

For complete installation instructions, consult the operation and installation guide for the specific SDI2 device. SDI2 devices connect to the control panel in parallel (Table 24).

These devices can share power with the control panel or be powered by a stand-alone power source.

Table 24: SDI2 Device Connections

Terminal	Function	Wire Color	Function
36	POWER +	Red	+12.0 VDC
35	DATA BUS 1	Yellow	Data
34	DATA BUS B	Green	Data
33	COMMON	Black	Common



A stand-alone power supply powering the SDI2 device must also be connected to a common terminal on the control panel.

Do not connect the earth ground for the stand-alone power supply to Terminal 10 on the control panel.

13.2.1 Open Wire Trouble on SDI2

The GV4 Series Control Panels can detect an open wire fault in the data communication lines of the SDI2 bus. Any open wire on Terminals 34 or 35 result in a system fault trouble display on

all keypads and a general SDI Trouble event sent to the central station

13.3 B208 Octo-input Module

The Octo-input module is an 8 point expansion device that connects to the control panel through the SDI2 bus. This module is supervised and communicates back to the control panel all point status changes. The module's expansion points work the same as the points on the control panel.

Review the information in *Section 6.0 Power Outputs* on page 30 to ensure that there is enough power for the B208 and other powered devices you want connected to the system.

On the D9412GV4 control panel, you can add up to 24 Octo-input modules. On the D7412GV4 control panel, you can add up to 7 Octo-input modules. On the D7212GV4, you can add up to 3 Octo-input modules.

The B208 Octo-input Modules connect to the SDI2 bus on the control panel using Terminals 33 through 36, or using the SDI2 interconnect wiring connector. You can connect more than one module to the control panel by wiring them in parallel. Refer to the *B208 Installation and Operation Guide* (P/N: F01U215232) for wiring instructions.

13.3.1 Address Settings



The control panel reads rotary switch setting changes on power up. If you change the switches after installation and applying power to the control panel, you must cycle the power to the control panel.

The B208 rotary switches provide a tens and a ones setting for the module's address. For single-digit address numbers 0-9, set the tens switch to 0 and the ones digit to the appropriate number. Refer to *Figure 28* on page 69.

Figure 28: B208 Switches Set to Address 9



Valid B208 addresses are dependent on the number of points allowed by a particular control panel. Refer to *Table 29* on page 83.

B208 Octo-input modules cannot support some point assignments, for example points 9 and 10, 19 and 20, 29 and 30, etc. These inaccessible point assignments can be supported on the ZONEX bus or SDI2 Wireless RF points. On the GV4 Series Control Panels, each off-board point assignment can be assigned a Point Source to define its bus type.

13.3.2 Supervision

Supervision of B208 Octo-input Modules on the SDI2 bus is enabled automatically when the Point Source of a point assignment is set to Octo-input. Each Octo-input module supports a fixed range of point assignments. Refer to *Table 29* on page 83 for point to module assignments. Any failure to receive an expected response from an SDI2 module results in a system fault display on all keypads and a module specific SDI FAULT event sent to the central station.

13.4 B308 Octo-output Module

The B308 Octo-output module is an 8 relay expansion device that connects to control panels through the SDI2 bus. This module is supervised and communicates to the control panel to provide 8 independently controlled outputs. Each output can operate as either normally open or normally closed.

Review the information in *Section 6.0 Power Outputs* on page 30 to ensure that there is enough power for the B308 and other powered devices you want connected to the system.

On the D9412GV4 control panel, you can add up to 12 Octo-output modules. On the D7412GV4 control panel, you can add up to 6 Octo-output modules. On the D7212GV4 control panel, you can add up to 2 Octo-output modules.

13.4.1 Address Settings



The control panel reads rotary switch setting changes on power up. If you change the switches after installation and applying power to the control panel, you must recycle the power to the control panel.

The B308 rotary switches provide a tens and a ones setting for the module's address. For single-digit address numbers 0 through 9, set the tens switch to 0 and the ones digit to the appropriate number. Refer to *Figure 29* on page 70. Only address 01 through 32 are valid for the B308 module.

Figure 29: B308 Switches Set to Address 9



Valid B308 addresses are dependent on the number of relays allowed by a particular control panel.

B308 Octo-output modules cannot support some relay outputs, for example relays 9 and 10, 19 and 20, 29 and 30, etc. These inaccessible outputs can be supported on the ZONEX bus. On the control panels, each off-board relay can be assigned to a destination to define its bus type (SDI2 or ZONEX).

Table 25: B308 Valid Relay Numbers

B308 Module#	Supported Relays
1	11 - 18
2	21 - 28 ²
3	31 - 38
4	41 - 48
5	51 - 58
6	61 - 68 ¹
7	71 - 78
8	81 - 88
9	91 - 98
10	101 - 108
11	111 - 118
12	121 - 128

¹ For the D7412GV4, only 4 outputs are available at address 6.
² For the D7212GV4, only 4 outputs are available at address 2.

13.4.2 Supervision

Supervision of B308 Octo-output Modules on the SDI2 bus is enabled automatically when the Relay Destination of an off-board relay is set to Octo-output. Each Octo-output module supports a fixed range of off-board relays. Refer to *Table 25* on page 71 for relay to module assignments. Any failure to receive an expected response from an SDI2 module results in a system fault display on all keypads and a module specific SDI FAULT event sent to the central station.

13.5 B420 Ethernet Communication Module

The Bosch Security Systems, Inc. B420 Ethernet Communication Module is a four-wire powered SDI2 device that provides connection for two-way communication over Ethernet networks to the control panels. You can add up to two B420 Ethernet Communication Modules.

13.5.1 Address and Emulation Settings

The B420 address switches provide a single-digit setting for the module's address. The module uses addresses 0 through 9. Refer to *Figure 30* on page 71.

Figure 30: B420 Switch Set to Address 1

The B420 has specific rotary switch settings for SDI Addresses 88 and 92 or SDI2 Addresses 1 and 2 when used to communicate with Remote Programming Software (RPS) or with a central station network receiver. Refer to *Table 26* for the correct switch settings. When the Reset Pin (labeled S1) is closed, all SDI communication module addresses are automatically enabled for RPS communication without restriction.

Table 26: B420 Address and Emulation Settings

Rotary Switch Setting	Bus Type and Setting
0	Default
1	SDI2 – Address 1
2	SDI2 – Address 2
3*	SDI – Address 80
4*	SDI – Address 88
5*	SDI – Address 92
6*	N/A for GV4
7*	N/A for GV4
8*	N/A for GV4
9*	N/A for GV4

* Emulates DX4020 operation.

13.5.2 Supervision

Supervision of Ethernet Communication Modules at SDI2 Addresses 1 and 2 are enabled automatically when used to communicate with a central station network receiver. Supervision ensures reliable operation between the module and the control panel.

If supervised and the module does not respond to control panel supervision polls, then a system fault message appears at the keypads. A corresponding report is sent to the central station.

13.5.2 Local RPS Programming

Use the B420's IP Direct connect feature to locally connect with RPS. This connection method requires a direct IP connection from the

PC to the B420's Ethernet port, which requires you to remove the Ethernet cable that connects the B420 to the Web for the duration of the IP direct connection. Be sure to reconnect the B420 to the internet when you finish.

The IP Direct connection for RPS uses the B420's AutoIP configuration. Refer to the *B420 Installation and Operation Guide* for configuration information. This connection method also allows diagnostic and history retrieval.

13.5.3 Ethernet Communications Module Faults

With a B420 Ethernet Communications Module installed, several services are made available to the GV4 series control panel. Any break in the Ethernet connection to a supervised B420 results in a system fault at the keypads indicating Open Cable trouble. An SDI FAULT event is sent to the central station, if enabled.

If a Domain Name Server (DNS) is available on the network, a failure to resolve an individual Network Address host name results in a system fault at the keypads indicating DNS ERROR ##. The error number represents the communication module and path destination combination that failed. Refer to the *D9412GV4/D7412GV4/D7212GV4 Program Entry Guide* for details on communication module/path destination combinations. A failure to resolve the domain name used for RPS Network Address is displayed on the keypads as DNS ERROR 99.

If a B420 fails all communication with the DNS, a system fault indicating Network Module # Address Error will be displayed on all keypads and a SDI TROUBLE event is sent to the central stations, if enabled.

13.6 B820 SDI2 Inovonics Interface Module

The B820 SDI2 Inovonics Interface Module allows a control panel to interface with an Inovonics EN4200 EchoStream Serial Receiver through the SDI2 bus. You can add up to 1 B820 module to a control panel.

The address switch determines the address for the B820 module. The control panel requires the module's address for communications. The B820 address switches provide a single-digit setting for the module's address. The module uses addresses 1 through 4. Addresses 0 and 5 through 9 are invalid. When connected to a GV4

Series Control Panel, only addresses 1 and 2 are valid. Refer to *Figure 31* on page 72.

Figure 31: B820 Switch Set to Address 1



13.7.1 Supervision

Supervision of a B820 SDI2 Inovonics Interface Module is enabled automatically when at least one RF device is enrolled. Available RF devices on the GV4 Series Control Panel are RF Repeaters, wireless points, or user keyfobs. Any failure to receive an expected response from an SDI2 module results in a system fault display on all keypads and an SDI Fault event sent to the central station.

13.7.2 Wireless Receiver Faults

The B820 SDI2 Inovonics Interface Module detects and reports ambient Radio Frequency (RF) interference as a system fault indicated as a jamming condition. This fault is accompanied by an RF Interference event sent to the central station.

The tamper input on the B820 module can, if enabled, create a system fault at the keypads. The B820 module can also generate a general trouble system fault. This fault indicates a non-recoverable problem has occurred that requires servicing. The trouble system fault and module tamper system fault are reported as a module specific SDI Fault to the central station.

13.7.3 Wireless Repeaters Faults

Each wireless repeater within range of the B820 SDI2 Inovonics Interface Module can report its AC status, battery status, and tamper input status. Each of these conditions has a corresponding system fault display at the keypads, and generates a module-specific SDI Fault event that is sent to the central station.

14.0 Installer Keypad Tools

The GV4 Series Control Panels do not support the D5200 Programmer. Instead, a limited local keypad programming mode is available.

The available keypad tools options include:

- Programming
- Service Bypass
- RP Points
- RF Repeaters
- RF Diagnostics
- IP Diagnostics

While installing or maintaining a control panel, it is sometimes necessary to change the configuration. To do so, a local keypad programming menu is available in the Service Menu. You can access the Service Menu when the control panel is in stand-by mode or while it is operating. Refer to the *D9412GV4/D7412GV4/D7212GV4 Program Entry Guide (P/N: F01U218312)* for an explanation of the Tools Menu.

Accessing Local Keypad Programming when the Control Panel is Operating (Reset Pin Open)

To access all keypad programming tools while the control panel is operating:

1. Disarm all areas in the control panel.
Local keypad programming is only accessible when all areas are disarmed.
2. At any D1255 or D1260 Keypad, press [9][9][ENTER] to access the Service Menu.
3. Advance the menu to the Tools Menu option, then press [ENTER] to enter the Tools Menu mode.
4. Enter the Service passcode when prompted and press [ENTER].
 - Advance through the Tool Menu to find the option you wish to use.

The Tools Menu option is only available when all areas in the control panel are disarmed.

Accessing Installer Keypad Tools when the Control Panel is in Standby Mode (Reset Pin Closed)

The control panel is in standby mode when the Reset pin is closed. Refer to *Figure 4* on page 18. While the control panel is in standby mode, you can access the Tools Menu through the Installer Menu at one of two keypads with the following restrictions:

- An unsupervised D1260 Keypad (all versions) at SDI Bus Address 8.
The D1260 Keypad does not support SDI Bus Address 16.
- An unsupervised D1255 Keypad (all versions) at SDI Bus Address 16.
If a D1255 is set to SDI Bus Address 8, then that keypad cannot be used to access the Service Menu.
- Only one keypad at a time is allowed to be in use.

To access the Programming menu through the Installer Menu when the control panel is in standby mode:

1. From the keypad (D1260 at SDI Address 8 or D1255 at SDI Address 16), enter the Service Passcode.
2. Advance the menu to the Programming option.
3. Press [ENTER] to enter Programming.

14.1 RPS Access Reports

When a program is sent to the control panel from RPS, the control panel sends a Prog Access OK report 10 sec after the Reset Pin is unlocked, or when the programmer disconnects. The prompt in routing must be programmed **Yes** to send this report.

15.0 Accessory Connector

Use the accessory connector to connect the D9412GV4 or D7412GV4 control panel to the D928 Dual Phone Line Switcher. The accessory connector is on the bottom right corner of the I/O board (Figure 32). The D928 lets the control panel use two telephone lines to send reports.

Refer to *Section 7.11 D928 Dual Phone Line Switcher* on page 34 for installation and operating instructions.

Figure 32: Accessory Connection on D9412GV4 and D7412GV4

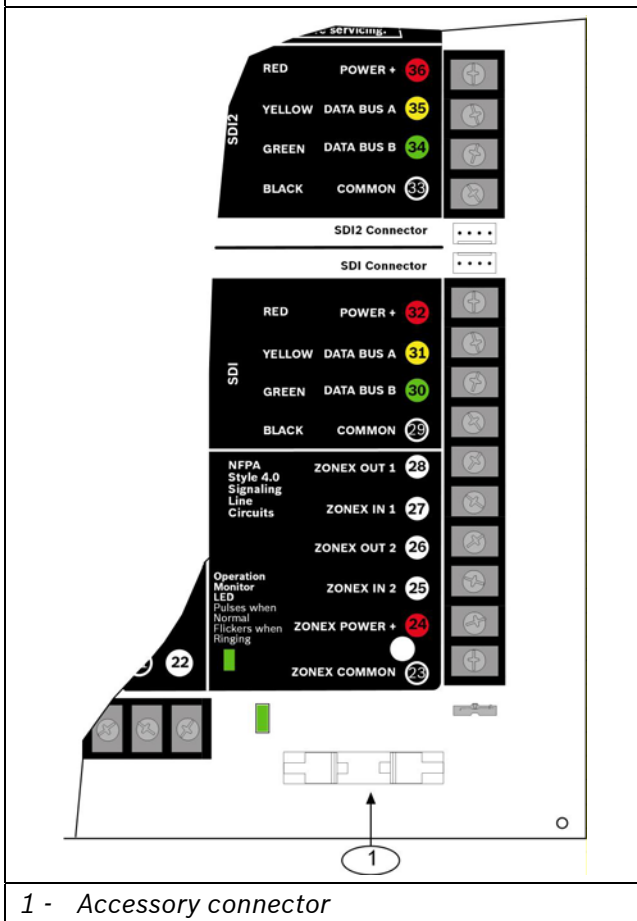

1 - Accessory connector

16.0 Faceplates

16.1 GV4 Series Faceplate

Figure 33: D9412GV4/D7412GV4/D7212GV4 Faceplate

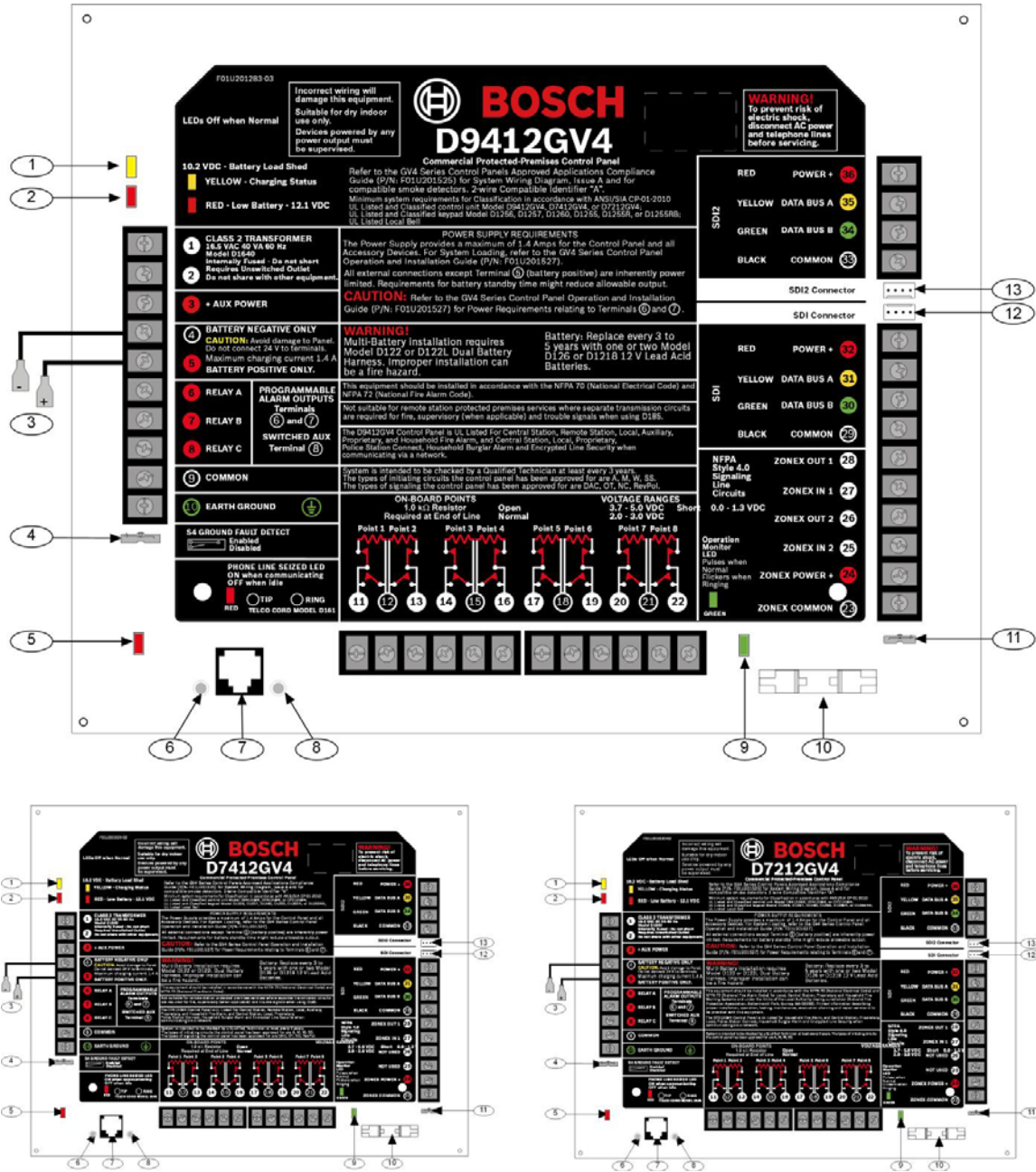

- 1 - Charging status LED (yellow)
- 2 - Low battery LED (red)
- 3 - Color-coded battery leads
- 4 - Ground fault detect enable
- 5 - Phone LED (red)
- 6 - Tip
- 7 - Telephone cord connector

- 8 - Ring
- 9 - Operation monitor LED (green)
- 10 - Accessory connector
- 11 - Reset pin
- 12 - SDI interconnect wiring connector
- 13 - SDI2 interconnect wiring connector

Appendix A: System Wiring Diagrams

A.1 Power Supply Side System Wiring

Figure 34: D9412GV4/D7412GV4/D7212GV4 Power Supply Side System Wiring (Power and Phone)

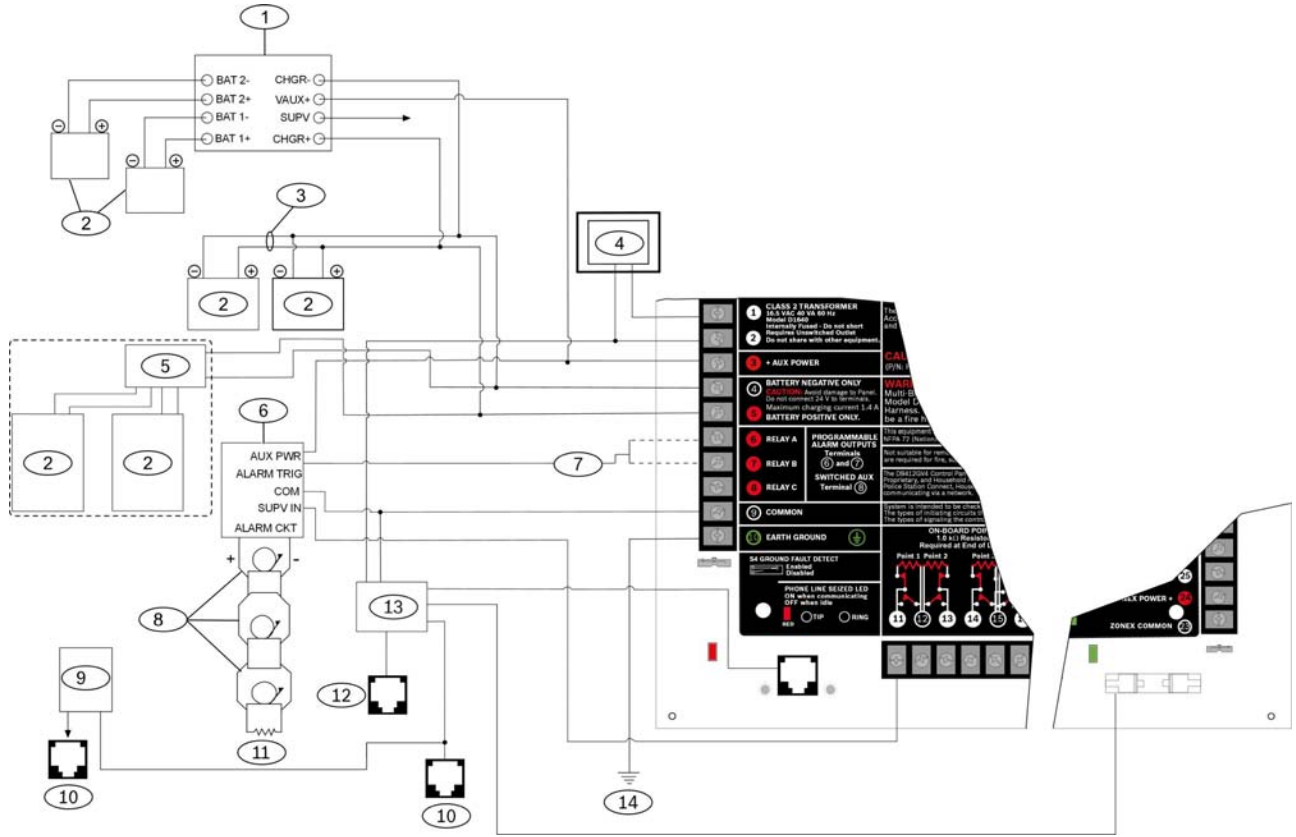

- | | |
|---|---|
| <ul style="list-style-type: none"> 1 - If required by local AHJ, connect D113 Battery Lead Supervision Module. 2 - Batteries 3 - D122 Dual Battery Harness, as required 4 - D1640 Transformer and D8004 Transformer Enclosure required for NFPA Applications 5 - D8132 Dual Battery Charger with two batteries (Batteries are not supervised.) 6 - D192G Bell Supervision Module 7 - To Relay A or Relay B | <ul style="list-style-type: none"> 8 - Listed Audible Signaling Devices rated at 12.0 VDC nominal (do not use vibrating type horns) 9 - C900V2(optional) 10 - RJ31X, secondary phone line (not available on the D7212GV4) 11 - 560 Ω, 2 W EOL Resistor (P/N: 15-03130-005) 12 - RJ31X, primary phone line 13 - D928 (not available on the D7212GV4) 14 - To earth ground |
|---|---|



Terminals 1, 2, and 11, and the Accessory Connector are power limited, supervised.
All external connections except Terminal 5 (battery positive) are power limited.

A.2 Input Points and Peripheral Devices Wiring Diagrams

Figure 35: D9412GV4/D7412GV4/D7212GV4 Input Points and Peripheral Devices System Wiring

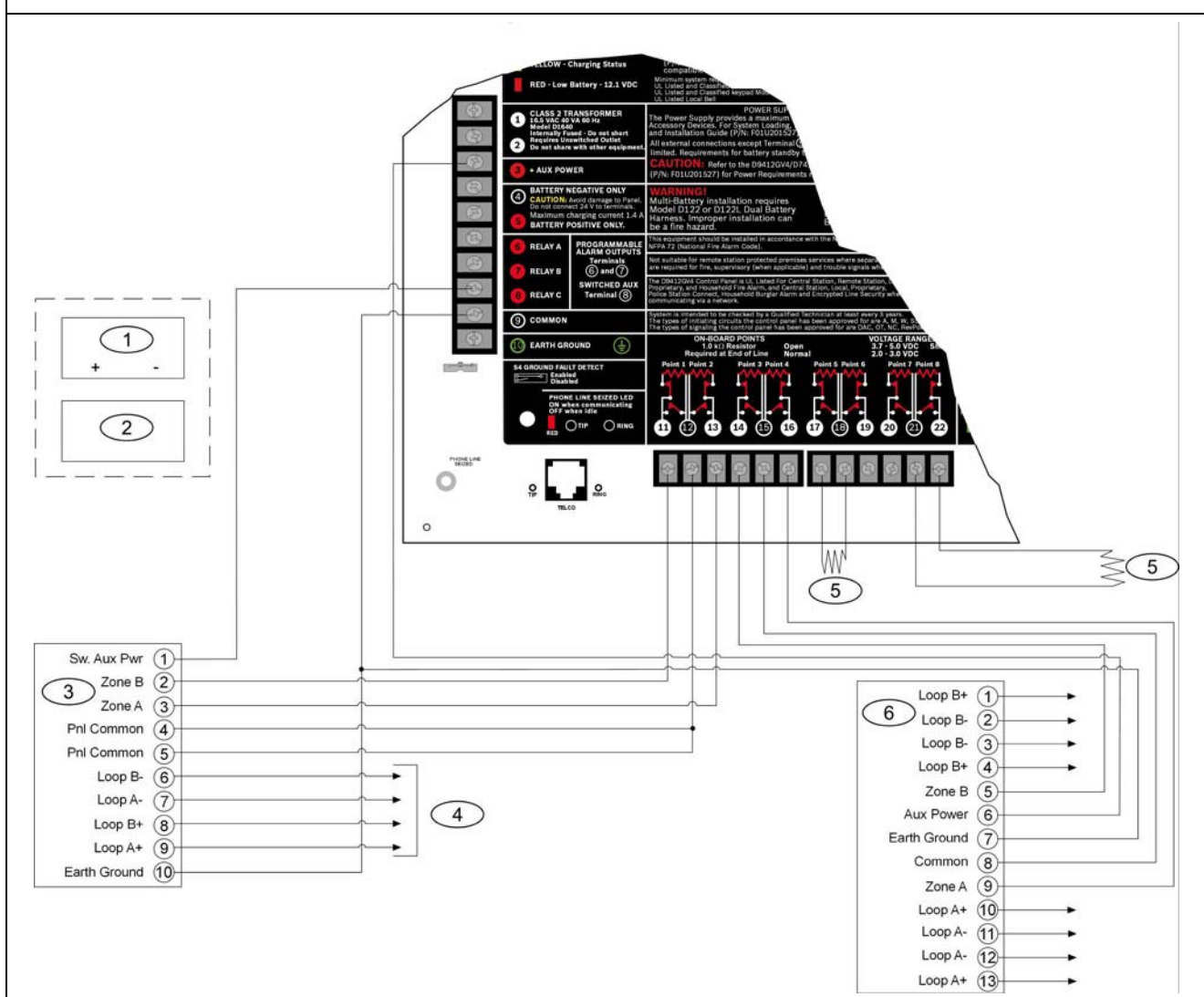

- 1 - (Optional): For 24 V applications use a UL 1481 listed, regulated, power-limited 24 VDC power supply with a D130 Relay Module. Refer to the D130 Installation Instructions (P/N: F01U072455) for correct wiring requirements.
- 2 - D130 Relay Module
- 3 - D125B Powered Loop Interface Module
- 4 - To UL Listed two-wire smoke detectors with a fire rated EOL resistor. Refer to Two-Wire Smoke Detectors in the D9412GV4/D7412GV4/D7212GV4 Approved Applications Compliance Guide (P/N: F01U201525) for a listing of compatible two-wire smoke detectors.

- 5 - 1k Ω EOL resistor (P/N: F01U033966): For typical burglar alarm applications.
- 6 - D129 Dual Class A Initiation Circuit Module: Provides optional Waterflow Alarm Retard feature. Not suitable for two-wire smoke detectors.



For D129, use zero retard except for waterflow devices.

All external connections except Terminal 5 (battery positive) are power limited.

A.3 SDI and Zonex Devices System Wiring System Wiring

Figure 36: D9412GV4 SDI and Zonex Devices System Wiring System Wiring

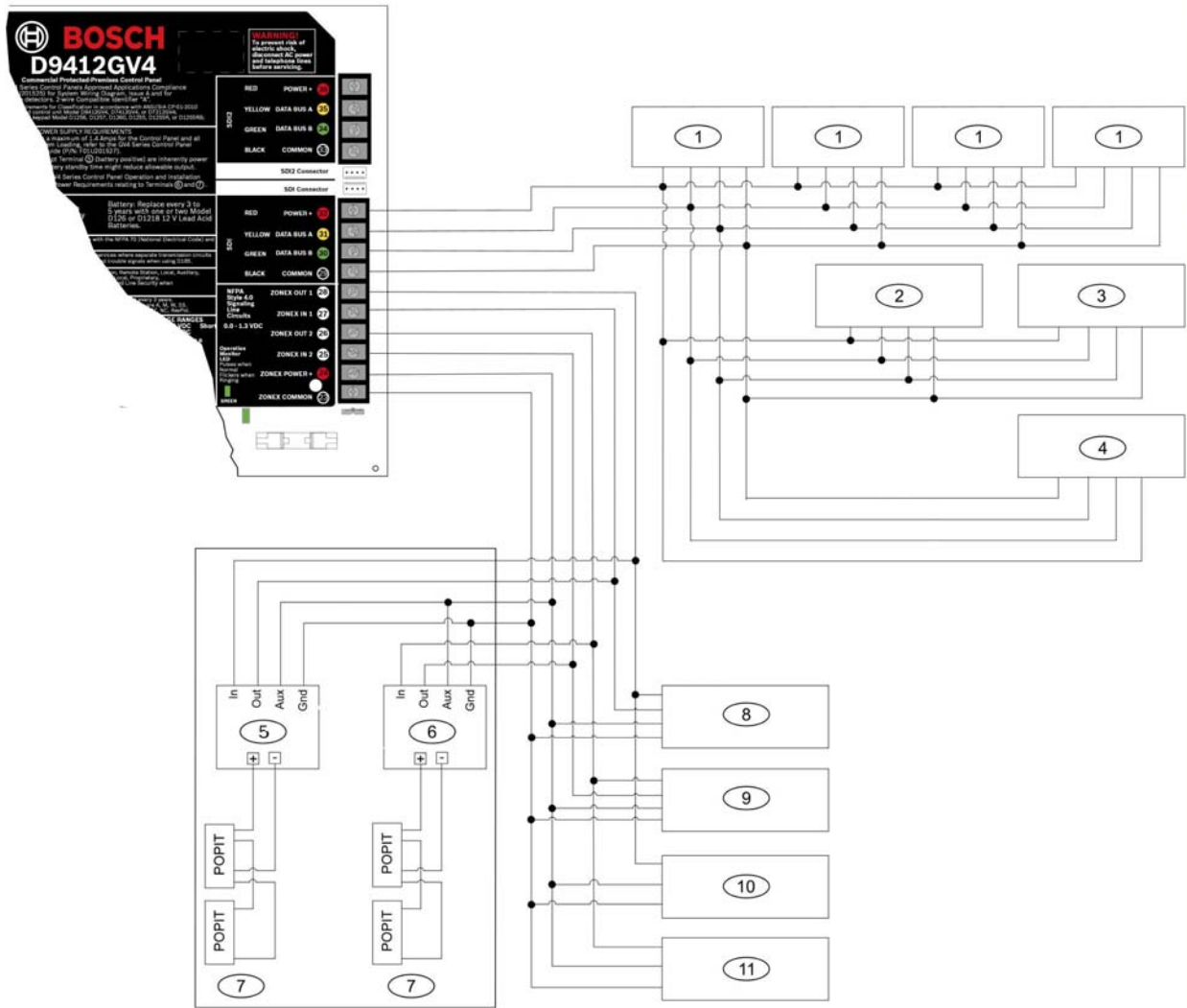

- | | |
|---|---|
| <p>1 - Up to 16 supervised D1255 (all versions), D1255RB, D1256, D1256RB Keypads, or D1257RB or D1257 Fire Annunciators, or up to 8 supervised D1260 Keypads (all versions)</p> <p>2 - Up to 8 D9210C Access Control Interface Modules</p> <p>3 - Up to 3 supervised 9131A Parallel Printer Interface Modules</p> <p>4 - Up to 3 DX4020, ITS-DX4020-G, or B420 Ethernet Communication Modules</p> | <p>5 - D8125 POPEX No.1</p> <p>6 - D8125 POPEX No. 2</p> <p>7 - Up to 119 D9127U/T POPITs</p> <p>8 - Zonex 1: 15 D8128Ds maximum*</p> <p>9 - Zonex 2: 15 D8128Ds maximum*</p> <p>10 - Zonex 1: Up to 8 D8129s maximum*</p> <p>11 - Zonex 2: Up to 8 D8129s maximum*</p> |
|---|---|

* The number of D8129 OctoRelays that can be connected to each zonex terminal on the control panel is limited by the number of D8128D OctoPOPITs connected to the same terminal. Refer to the *D8128D Installation Guide* (P/N: F01U070537) or the *D8129 Operation and Installation Guide* (P/N: F01U036302) for specific information.



Terminals 24 through 36 are power limited, supervised.

Fire and Intrusion devices must be on separate circuits. Refer to *ICP-SDI-9114 Installation Instructions* (P/N: F01U030068).

Figure 37: D7412GV4/D7212GV4 SDI and Zonex Devices System Wiring

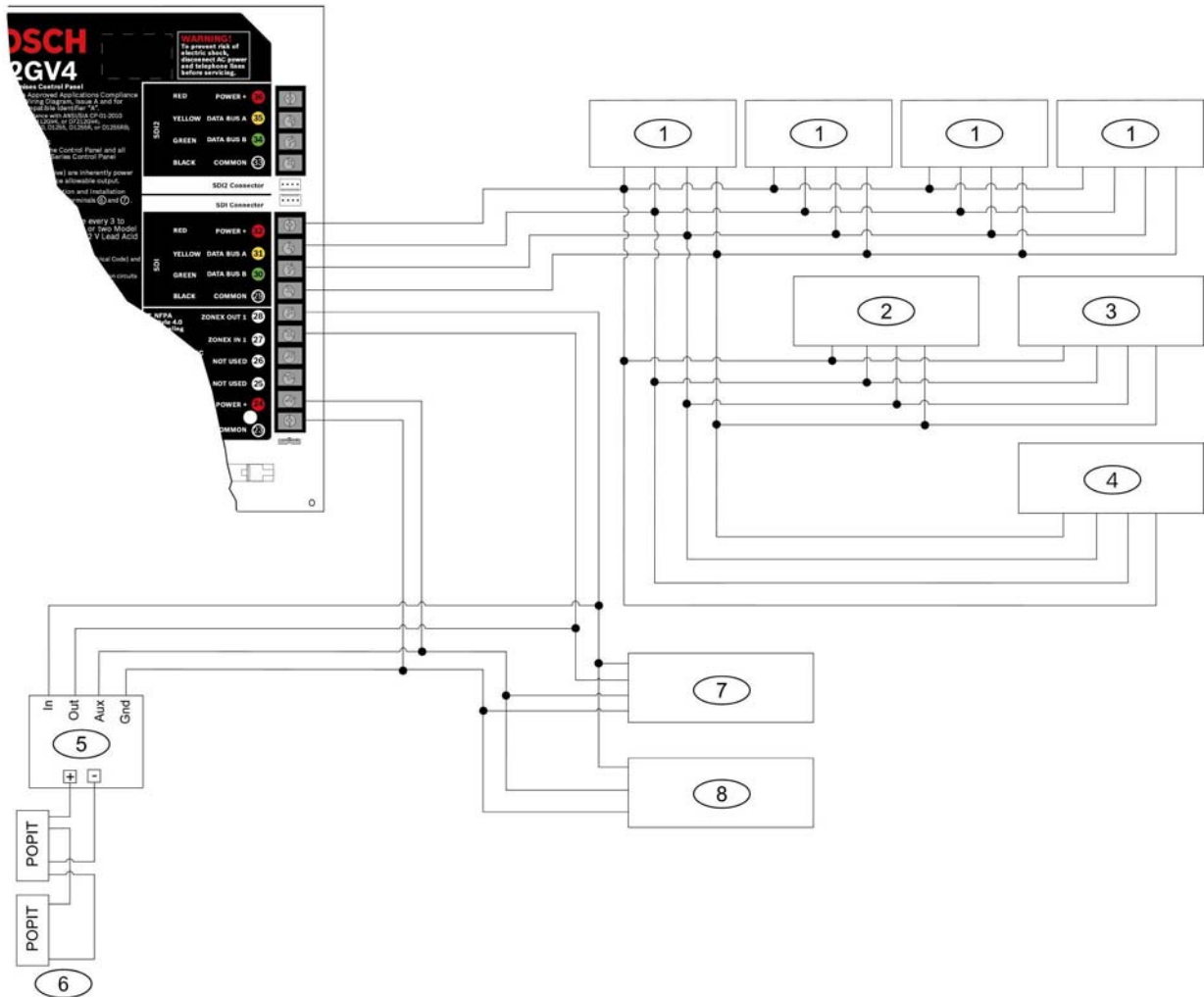

- | | |
|--|--|
| <ul style="list-style-type: none"> 1 - Up to 16 supervised D1255 (all versions), D1255RB, D1256, D1256RB Keypads, or D1257RB or D1257 Fire Annunciators, or up to 8 supervised D1260 Keypads (all versions) 2 - Up to 2 D9210C Access Control Interface Modules (not available on the D7212GV4) 3 - Up to 1 supervised 9131A Parallel Printer Interface Module 4 - Power limited, supervised | <ul style="list-style-type: none"> 5 - Up to two DX4020, ITS-DX4020-G, or B420 Ethernet Communication Modules 6 - Power limited 7 - D8125 POPEX No. 1 8 - Up to 67 D9127U/T POPITs 9 - Zonex 1: Up to 9 D8128Ds 10 - Zonex 1: Up to 8 D8129s maximum |
|--|--|

* The number of D8129 OctoRelays that can be connected to each zonex terminal on the control panel is limited by the number of D8128D OctoPOPITs connected to the same terminal. Refer to the *D8128D Installation Guide* (P/N: F01U070537) or the *D8129 Operation and Installation Guide* (P/N: F01U036302) for specific information.



Terminals 24 through 36 are power limited, supervised.

Fire and Intrusion devices must be on separate circuits. Refer to ICP-SDI-9114 Installation Instructions (P/N: F01U030068).

Figure 38: D9412GV4/D7412GV4/D7212GV4 SDI2 Devices System Wiring

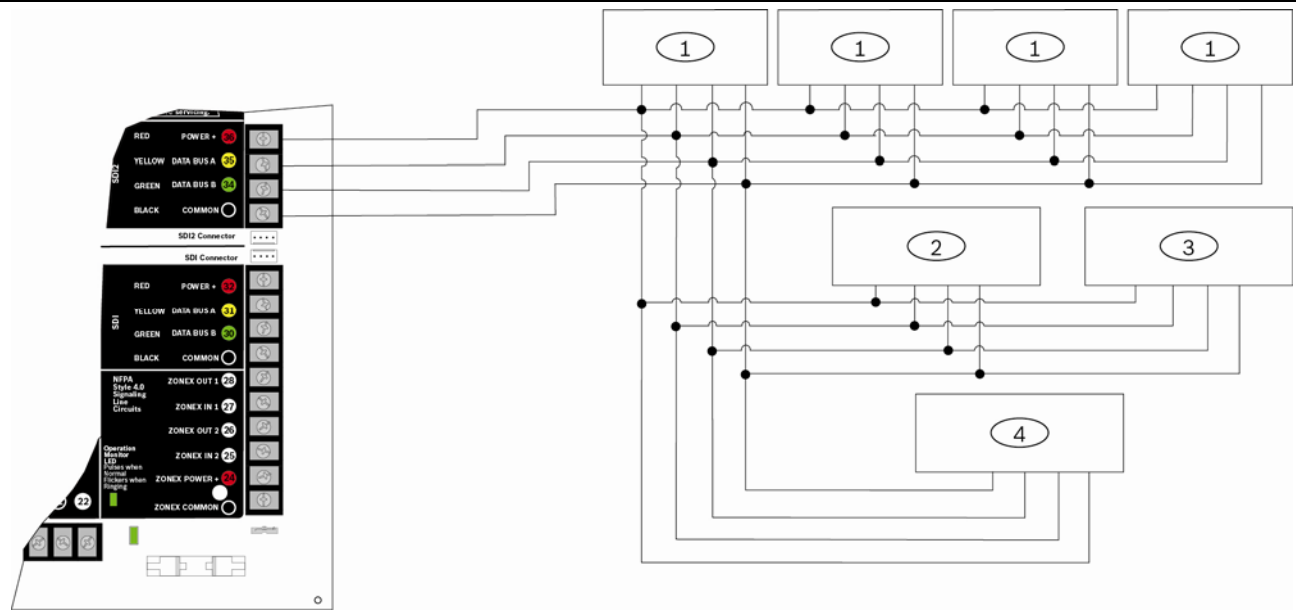

1 - Up to 24 B208 Octo-input Modules¹
 2 - Up to 12 B308 Octo-output Modules²

3 - Up to 2 B420 Ethernet Communication Modules
 4 - B820 SDI2 Inovonics Interface Module

¹The D7412GV4 supports up to 7 Octo-inputs. The D7212GV4 supports up to 3 Octo-inputs.

²The D7412GV4 supports up to 6 Octo-outputs. The D7212GV4 supports up to 2 Octo-outputs.



SDI2 Power Terminal 36 is power limited. SDI2 data Terminals 34 and 35 are supervised. Fire and Intrusion devices must be on separate circuits. Refer to *ICP-SDI-9114 Installation Instructions* (P/N: F01U030068).

Appendix B: Point Address Charts

B.1 Zonex 1 Points



Place the labels on the base of the POPIT. Do **not** attach labels to the POPIT cover.

A bullet (•) in the switch column indicates that the switch is set to ON.

D9127 POPITs can be used for Points 9 to 72; however, only D9127 POPITs can be used for Points 73 to 127.

D9127 POPITs have DIP switches 0 to 6.

Table 27: Zonex 1 Point Address Chart

Table 27: Zonex 1 Point Address Chart																							
Address ¹	Switch ²						Address ¹	Switch ²						Address ¹	Switch ²								
	0	1	2	3	4	5		6	0	1	2	3	4		5	6	0	1	2	3	4	5	6
009	•	•	•	•	•	•	•	049	•		•		•	•	•	089		•		•	•	•	•
010	•	•	•	•	•	•		050	•		•		•	•		090		•		•	•	•	
011	•	•	•	•	•		•	051	•		•		•		•	091		•		•	•		•
012	•	•	•	•	•			052	•		•		•			092		•		•	•		
013	•	•	•	•		•	•	053	•		•			•	•	093		•		•		•	•
014	•	•	•	•		•		054	•		•			•		094		•		•		•	
015	•	•	•	•			•	055	•		•				•	095		•		•			•
016	•	•	•	•				056	•		•					096		•		•			
017	•	•	•		•	•	•	057	•			•	•	•	•	097		•			•	•	•
018	•	•	•		•	•		058	•			•	•	•		098		•			•	•	
019	•	•	•		•		•	059	•			•	•		•	099		•			•		•
020	•	•	•		•			060	•			•	•			100		•			•		
021	•	•	•			•	•	061	•			•		•	•	101		•				•	•
022	•	•	•			•		062	•			•		•		102		•			•		
023	•	•	•				•	063	•			•			•	103		•					•
024	•	•	•					064	•			•				104		•					
025	•	•		•	•	•	•	065	•				•	•	•	105			•	•	•	•	•
026	•	•		•	•	•		066	•				•	•		106			•	•	•	•	
027	•	•		•	•	•	•	067	•				•		•	107			•	•	•		•
028	•	•		•	•			068	•			•				108			•	•	•		
029	•	•		•		•	•	069	•				•	•		109			•	•		•	•
030	•	•		•		•		070	•				•			110			•	•		•	
031	•	•		•			•	071	•					•		111			•	•			6
032	•	•		•				072	•							112			•	•			
033	•	•		•	•	•		073		•	•	•	•	•	•	113			•		•	•	•
034	•	•		•	•			074		•	•	•	•	•		114			•		•	•	
035	•	•		•		•		075		•	•	•	•		•	115			•		•		•
036	•	•		•				076		•	•	•	•			116			•		•		
037	•	•		•	•	•		077		•	•	•		•	•	117			•		•	•	•
038	•	•			•			078		•	•	•		•		118			•			•	
039	•	•				•		079		•	•	•			•	119			•				•
040	•	•						080		•	•	•				120			•				
041	•		•	•	•	•	•	081		•	•		•	•	•	121				•	•	•	•
042	•		•	•	•	•		082		•	•		•	•		122				•	•	•	
043	•		•	•	•		•	083		•	•		•		•	123				•	•		•
044	•		•	•	•			084		•	•		•			124				•	•		
045	•		•	•		•	•	085		•	•			•	•	125				•		•	•
046	•		•	•		•		086		•	•			•		126				•		•	
047	•		•	•			•	087		•	•				•	127				•			•
048	•		•	•				088		•	•					128 ³							

1 - Points 9 to 127 (D9412GV4); Points 9 to 75 (D7412GV4); Points 9-40 (D7212GV4)

2 - A dot (•) in the Switch column indicates the switch is set to ON.

3 - The control panel reserves Point 128 for internal use.

B.2 Zonex 2 Points



Place the labels on the base of the POPIT. Do **not** attach labels to the POPIT cover.

A number in the switch column indicates that the switch is set to ON.

Table 28: Zonex 2 Point Address Chart (D9412GV4)

Address ¹	Switch ²							Address ¹	Switch ²							Address ¹	Switch ²						
	0	1	2	3	4	5	6		0	1	2	3	4	5	6		0	1	2	3	4	5	6
129	169	209
130	170	210
131	171	211
132	172	212
133	173	213
134	174	214
135	175	215
136	176	216
137	177	217
138	178	218
139	179	219
140	180	220
141	181	221
142	182	222
143	183	223
144	184	224
145	185	225
146	186	226
147	187	227
148	188	228
149	189	229
150	190	230
151	191	231
152	192	232
153	193	233
154	194	234
155	195	235
156	196	236
157	197	237
158	198	238
159	199	239
160	200	240
161	201	241
162	202	242
163	203	243
164	204	244
165	205	245
166	206	246
167	207	247
168	208	248 ³

1 - Points 129 to 247 (D9412GV4 only).

2 - A dot (·) in the Switch column indicates the switch is set to ON.

3 - The control panel reserves Point 248 for internal use.

B.3 SDI2 Points

Not all off-board points supported by the control panel can be supported on B208 Octo-input modules. Points 9 and 10, 19 and 20, etc. can be supported by ZONEX bus or SDI2 Wireless points.

Table 29: SDI2 Points	
Octo-input Module Rotary Switch Setting	Supported Points
0	Disabled
1	11 - 18
2	21 - 28
3	31 - 38 ³
4	41 - 48
5	51 - 58
6	61 - 68
7	71 - 78 ²
8	81 - 88
9	91 - 98
10	101 - 108
11	111 - 118
12	121 - 128
13	131 - 138
14	141 - 148
15	151 - 158
16	161 - 168
17	171 - 178
18	181 - 188
19	191 - 198
20	201 - 208
21	211 - 218
22	221 - 228
23	231 - 238
24	241 - 248 ¹

¹ The D9412GV4 supports points 1 to 247 and modules 1-24. Terminate point 248 with an EOL resistor.

² The D7412GV4 supports points 1 to 75 and modules 1 - 7. Terminate points 76, 77, and 78 with EOL resistors.

³ The D7212GV4 supports points 1 to 40 and modules 1 - 3.

Appendix C: Specifications

C.1 Control Panel Power Supply

Table 30: Control Panel Power Supply Specifications			
Voltage Input (Power Supply)¹	Primary:	Terminals 1 and 2	16.5 VAC 40 VA class 2 plug-in transformer (D1640)
	Secondary:	Terminals 4 and 5	Sealed lead-acid rechargeable battery (12.0 VDC, 7 Ah or 12.0 VDC, 17.2 or 18 Ah). The control panel supports up to two 12.0 VDC, 7 Ah batteries using the D122 Dual Battery Harness or two D1218 (12.0 VDC, 17.2 or 18 Ah) batteries using a D122.
Current Requirements	Control Panel: Idle 225 mA; Alarm 300 mA Refer to the <i>Current Rating Chart for Standby Battery Calculations</i> section in the <i>D9412GV4/D7412GV4/D7212GV4 Approved Applications Compliance Guide (P/N: F01U201525)</i> for the current draw requirements of other system components.		
Power Outputs²	All external connections are power-limited except battery terminals.		
	Continuous Power Outputs	Terminals 1 – 4, 6 - 36	1.4 A maximum at 12.0 VDC nominal (continuous supply) total for all devices and outputs supplied at Terminals 3, 24, and 32 through 36.
	Alarm Power Output	Terminals 6 and 7	2.0 A maximum at 12.0 VDC nominal output. Output can be steady or one of three pulsed patterns depending on programming. Refer to <i>Relays</i> in the <i>D9412GV4/D7412GV4/D7212GV4 Program Entry Guide (P/N: F01U218312)</i> .
	Switched Aux Power	Terminal 8	1.4 A maximum at 12.0 VDC nominal output. Continuous output is interrupted by Sensor Reset or alarm verification depending on programming. Refer to <i>Relays</i> in the <i>D9412GV4/D7412GV4/D7212GV4 Program Entry Guide (P/N: F01U218312)</i> .
	Fire and Fire/Burglary Systems	To comply with UL 985 and 864 listing standards for fire alarm systems (effective March 1, 1989), the total combined continuous and alarm current draw for the system during alarm conditions must be limited to 1.4 A provided by the primary power supply (rectified AC). If current draw for the system exceeds 1.4 A, remove connected devices until the current draw falls below 1.4 A. Then, connect the removed devices to a D8132 Battery Charger Module or to an external power supply (refer to Figure 25: External Power to SDI Devices on page 64).	
¹ Requires a UL Listed power supply.			
² For UL 864 applications, refer to <i>Table 3</i> on page 11 for compatible devices.			
Minimum Operating Voltage	10.2 VDC		
SDI Bus	SDI Bus A+:	9 VDC 4572 m (15000 ft) maximum	
	SDI Bus B-:	9 VDC 4572 m (15000 ft) maximum	
SDI2 Bus	SDI2 Bus A+:	9 VDC 4572 m (15000 ft) maximum	
	SDI2 Bus B-:	9 VDC 4572 m (15000 ft) maximum	
Telephone Connections	Connection: Two Telco lines:	RJ31X or RJ38X jack can connect the control panels. Bosch Security Systems, Inc. D928 Dual Phone Line Module required for two phone line service on D9412GV4 and D7412GV4. Supervision supplied by the control panel.	
Battery Discharge/Recharge Schedule	Discharge Cycle	13.9 VDC 13.8 VDC 12.1 VDC 10.2 VDC 10.0 VDC	Charging float level. Charging status LED on. Low Battery and AC Fail Reports if programmed. Low Battery LED on. Minimum operational voltage Battery load shed (processing functions continue if AC is present).
	Recharge Cycle	AC ON 13.7 VDC 13.9 VDC	Load shed relay resets, battery charging begins, Battery Trouble and AC Restoral Reports sent. Battery Restoral Report sent, Low Battery LED off. Charging status LED off, battery float charged.
Environmental	Temperature:	0°C to +50°C (+32°F to +122°F)	
	Relative Humidity:	Maximum 93% non-condensing	
Arming Stations	D720/D720B Keypads, D1255/D1255B/D1255RB Keypads, D1256/D1256RB Fire Keypads; D1257/D1257RB Fire Alarm Annunciators; D1260/D1260B Keypads; Keypads; Keypads; Keyfobs.		
Point Thresholds	On-board Points 1 to 8	Open	Greater than 3.7 VDC, but less than 5.0 VDC.
		Normal	Greater than 2.0 VDC, but less than 3.0 VDC.
		Short	Greater than 0.0 VDC, but less than 1.3 VDC.
Compatible Enclosures	D8103 Universal Enclosure, D8109 Fire Enclosure, D8108A Attack Resistant Enclosure, BATB-40 and BATB-80 Battery Boxes.		

C.2 Terminal Wiring

Table 31: Terminal Wiring Requirements

Terminal No	Terminal Description	Requirements
1	AC	18 AWG min (up to 14 AWG max)
2	AC	18 AWG min (up to 14 AWG max)
3	+ AUX POWER	Terminal accommodates 14 to 22 AWG, use appropriate wire size based on current
4	BATTERY -	Bosch supplied wire lead, included with panel
5	BATTERY +	Bosch supplied wire lead, included with panel
6	RELAY A	Terminal accommodates 14 to 22 AWG, use appropriate wire size based on current
7	RELAY B	Terminal accommodates 14 to 22 AWG, use appropriate wire size based on current
8	RELAY C	Terminal accommodates 14 to 22 AWG, use appropriate wire size based on current
9	COMMON	Terminal accommodates 14 to 22 AWG, use appropriate wire size based on current
10	EARTH GROUND	14 to 16 AWG
11	POINT 1	Terminal accommodates 14 to 22 AWG, use appropriate wire size based on loop resistance less than 100 Ω
12	POINT 1/2 COMMON	Terminal accommodates 14 to 22 AWG, use appropriate wire size based on loop resistance less than 100 Ω
13	POINT 2	Terminal accommodates 14 to 22 AWG, use appropriate wire size based on loop resistance less than 100 Ω
14	POINT 3	Terminal accommodates 14 to 22 AWG, use appropriate wire size based on loop resistance less than 100 Ω
15	POINT 3/4 COMMON	Terminal accommodates 14 to 22 AWG, use appropriate wire size based on loop resistance less than 100 Ω
16	POINT 4	Terminal accommodates 14 to 22 AWG, use appropriate wire size based on loop resistance less than 100 Ω
17	POINT 5	Terminal accommodates 14 to 22 AWG, use appropriate wire size based on loop resistance less than 100 Ω
18	POINT 5/6 COMMON	Terminal accommodates 14 to 22 AWG, use appropriate wire size based on loop resistance less than 100 Ω
19	POINT 6	Terminal accommodates 14 to 22 AWG, use appropriate wire size based on loop resistance less than 100 Ω

20	POINT 7	Terminal accommodates 14 to 22 AWG, use appropriate wire size based on loop resistance less than 100 Ω
21	POINT 7/8 COMMON	Terminal accommodates 14 to 22 AWG, use appropriate wire size based on loop resistance less than 100 Ω
22	POINT 8	Terminal accommodates 14 to 22 AWG, use appropriate wire size based on loop resistance less than 100 Ω
23	ZONEX COMMON	22 AWG min (up to 14 AWG max)
24	ZONEX POWER	22 AWG min (up to 14 AWG max)
25	ZONEX IN 2*	22 AWG min (up to 14 AWG max)
26	ZONEX OUT 2*	22 AWG min (up to 14 AWG max)
27	ZONEX IN 1	22 AWG min (up to 14 AWG max)
28	ZONEX OUT 1	22 AWG min (up to 14 AWG max)
29	SDI COMMON	Terminal accommodates 14 to 22 AWG, use appropriate wire size based on peripheral device current
30	SDI DATA BUS B	22 AWG min (up to 14 AWG max)
31	SDI DATA BUS A	22 AWG min (up to 14 AWG max)
32	SDI POWER	Terminal accommodates 14 to 22 AWG, use appropriate wire size based on peripheral device current
33	SDI2 COMMON	Terminal accommodates 14 to 22 AWG, use appropriate wire size based on peripheral device current
34	SDI2 DATA BUS B	22 AWG min (up to 14 AWG max)
35	SDI2 DATA BUS A	22 AWG min (up to 14 AWG max)
36	SDI2 POWER	Terminal accommodates 14 to 22 AWG, use appropriate wire size based on peripheral device current
*D9412GV4 only. Terminals 25 and 26 are NOT USED on D7412GV4 and D7212GV4 Control Panels.		

Notes



Bosch Security Systems, Inc.

130 Perinton Parkway

Fairport, NY 14450

USA

www.boschsecurity.com

© Bosch Security Systems, Inc., 2012